

TABLE OF CONTENTS

	<u>Page</u>
Assessment Systems in Career Development Programs, Jim Athen. . .	1
Vocational Assessment: What Can Be Gained From It?, Donn Brolin. . . . .	7
Assessment Systems in Career Development Programs, Dennis J. Dunn . . . . .	17
The Singer Graflex System, Stanley Hienemann. . . . .	32
Use of the Singer System for Career Exploration, Donald Anderson and Bruce Stoll. . . . .	40
Singer/Graflex System - Its Use in Correctional Programs in Wisconsin, Ricardo G. Cerna. . . . .	51
The Use of Singer Graflex with the Mentally Retarded, Richard Schoonover . . . . .	59
JEVS, Harold Kulman, Franklin Drachman, and Fred Stabene. . . .	63
The JEVS System in a Community College, Dennis Krehbiel . . . .	67
The Tower System, Bernard Rosenberg . . . . .	73
Comparison of the JEVS, Singer/Graflex and Tower Work Evaluation Systems, Dennis Dunn . . . . .	80
The Wide Range Employment Sample Test, Raymond E. Morley. . . .	89
Talent Assessment Tests, Wilton E. and Maurine K. Nighswonger .	96
APEX - The Office: Reality Training Through Simulation, Raymond E. Morley. . . . .	111
Observations and Implications, Dan Kroloff. . . . .	116

ED106654

# Vocational Assessment Systems

U S DEPARTMENT OF HEALTH, EDUCATION & WELFARE  
NATIONAL INSTITUTE OF EDUCATION  
THIS DOCUMENT HAS BEEN REPRODUCED EXACTLY AS RECEIVED FROM THE PERSON OR ORGANIZATION ORIGINATING IT. POINTS OF VIEW OR OPINIONS STATED DO NOT NECESSARILY REPRESENT OFFICIAL NATIONAL INSTITUTE OF EDUCATION POSITION OR POLICY

## Application in Programs Serving Special Needs Populations

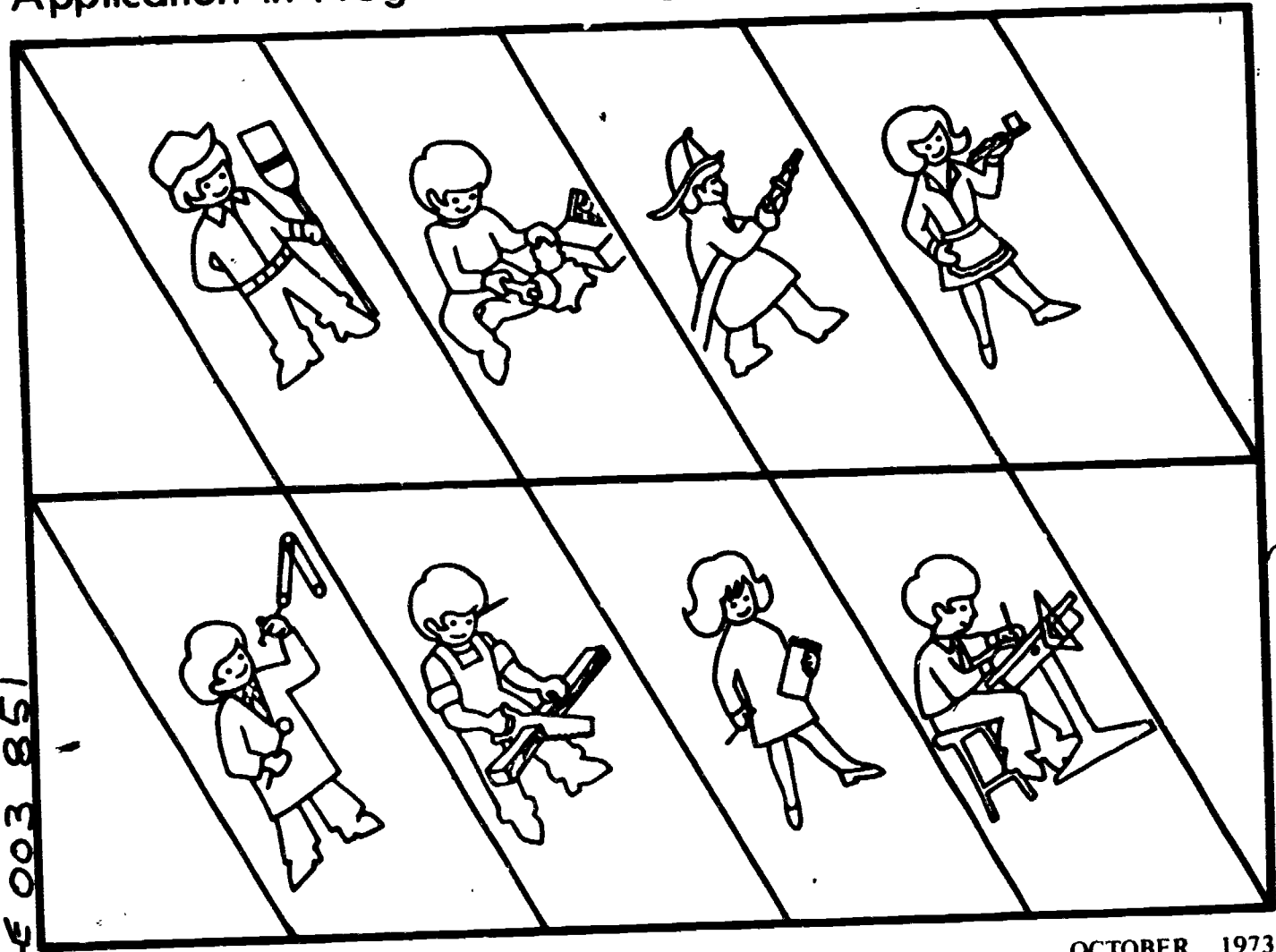

CE 003 851

IOWA DEPARTMENT OF PUBLIC INSTRUCTION

OCTOBER, 1973

State of Iowa  
DEPARTMENT OF PUBLIC INSTRUCTION  
Special Needs Section  
Grimes State Office Building  
Des Moines, Iowa 50319

STATE BOARD OF PUBLIC INSTRUCTION

Mrs. Virgil E. Shepard, President, Allison  
T. J. Heronimus, Vice-President, Grundy Center  
Robert J. Beecher, Creston  
Mrs. Richard G. Cole, Decorah  
Mrs. Jolly Ann Davidson, Clarinda  
Ronald P. Hallock, West Des Moines  
Virginia Harper, Fort Madison  
Mrs. Earl G. Sievers, Avoca  
John E. van der Linden, Sibley

**ADMINISTRATION**

Robert D. Benton, State Superintendent, and Executive Officer of the  
State Board of Public Instruction  
David H. Bechtel, Administrative Assistant  
Richard N. Smith, Deputy State Superintendent

Pupil Personnel Services Branch

Drexel D. Lange, Associate Superintendent  
Dan Kroloff, Chief, Special Needs Section  
Raymond E. Morley, Consultant, Special Needs Section  
Bill Walter, Consultant, Special Needs Section

As authorized by the Vocational Education Act of 1963,  
amended in 1968. and in cooperation with:

Area Schools and Career Education Branch

William M. Baley, Associate Superintendent  
W.O. Schuermann, Director, Career Education  
Jim Athen, Assistant Director, Career Education

Prepared by:

Raymond E. Morley, Consultant, Special Needs

## IOWA INVITATIONAL WORKSHOP

### ASSESSMENT SYSTEMS IN CAREER DEVELOPMENT PROGRAMS

March 26 and 27, 1973  
Holiday Inn, Council Bluffs, Iowa

#### SPEAKERS

Donald J. Anderson, Counselor, Hawkeye Institute of Technology,  
Waterloo, Iowa  
Jim Athen, Assistant Director, Career Education, Department of Public  
Instruction, Des Moines, Iowa  
Donn Brolin, Associate Professor, University of Missouri - Columbia,  
Columbia, Missouri  
Ricardo G. Cerna, Vocational Evaluator, Wisconsin State Prison,  
Malone, Wisconsin  
Franklin Drachman, Vocational Research Institute, Philadelphia,  
Pennsylvania  
Dennis Dunn, Research and Training Center, Department of Rehabilitation  
and Manpower Services, University of Wisconsin - Stout, Menomonie,  
Wisconsin  
Stanley Hienemann, Consultant, Singer Graflex System, Graflex Evaluation  
and Training Division, Rochester, New York  
Dennis L. Krehbiel, Director of Career Evaluation Center, Ankeny, Iowa  
Dan Kroloff, Chief, Special Needs Section, Department of Public Instruction,  
Des Moines, Iowa  
Harold Kulman, Vocational Research Institute, Philadelphia, Pennsylvania  
Richard Schoonover, Director of the Pottawattamie Career Evaluation Project,  
Council Bluffs, Iowa  
Fred Stabene, Vocational Research Institute, Philadelphia, Pennsylvania  
Bruce Stoll, Special Needs Coordinator, Hawkeye Institute of Technology,  
Waterloo, Iowa

#### SPONSORS

Pottawattamie, Shelby, and Cass County Boards of Education - Iowa  
Special Needs Section, Career Education Division, and Rehabilitation  
and Education Services Branch of the Iowa Department of Public  
Instruction  
Research and Training Center - Department of Rehabilitation and  
Manpower Services - University of Wisconsin, Stout  
Department of Guidance and Personnel Services, University of Missouri,  
Columbia

The majority of the proceedings of the workshop held in Council Bluffs, Iowa, March 26th and 27th were compiled and edited for this publication. Scripts from films and slide-tape presentations were not included. Information on the Wide Range Achievement Test, APEX, and Talent Assessment Programs was added to supplement the information provided during the workshop.

This material was compiled and printed to provide educators and other professional personnel information on career assessment systems. However, it should be recognized that the descriptive information that has been included may change periodically since revisions are being made to improve the systems. The information in this publication was accurate as of March 22th, 1973. Up-to-date information should be requested from the distributors.

TABLE OF CONTENTS

	<u>Page</u>
Assessment Systems in Career Development Programs, Jim Athen. . .	1
Vocational Assessment: What Can Be Gained From It?, Donn Brolin. . . . .	7
Assessment Systems in Career Development Programs, Dennis J. Dunn . . . . .	17
The Singer Graflex System, Stanley Hienemann. . . . .	32
Use of the Singer System for Career Exploration, Donald Anderson and Bruce Stoll. . . . .	40
Singer/Graflex System - Its Use in Correctional Programs in Wisconsin, Ricardo G. Cerna. . . . .	51
The Use of Singer Graflex with the Mentally Retarded, Richard Schoonover . . . . .	59
JEVS, Harold Kulman, Franklin Drachman, and Fred Stabene. . . .	63
The JEVS System in a Community College, Dennis Krehbiel . . . .	67
The Tower System, Bernard Rosenberg . . . . .	73
Comparison of the JEVS, Singer/Graflex and Tower Work Evaluation Systems, Dennis Dunn . . . . .	80
The Wide Range Employment Sample Test, Raymond E. Morley. . . .	89
Talent Assessment Tests, Wilton E. and Maurine K. Nighswonger .	96
APEX - The Office: Reality Training Through Simulation, Raymond E. Morley. . . . .	111
Observations and Implications, Dan Kroloff. . . . .	116

Assessment Systems  
in  
Career Development Programs

Jim Athen  
Assistant Director, Career Education  
Iowa Department of Public Instruction

Presented at the Iowa Invitational Workshop  
on Assessment Systems and Career Development Programs

Council Bluffs, Iowa  
March 26-27, 1973

When the Special Needs Section staff approached me on the possibility of my meeting with you this evening, they indicated several areas that might be appropriate. A few of those areas were:

- (1) What is the outlook for assessment programs?
- (2) How much attention has been given to assessment in Vocational Education?
- (3) Where do assessment programs fit into the funding structure?
- (4) Who is to give leadership and direction to assessment efforts?

These appear to be very appropriate and pertinent points to raise. Before we move into comments on each, let's digress just a bit and see if we are all on the same wave length regarding this subject at hand.

This conference is centered around the subject of "Vocational Assessment." Are we together on purpose? What are we after? What do we wish to accomplish as a result of being here? How do our efforts relate to, or complement the direction being established for the implementation of career education?

When we use the term "Vocational Assessment" are we using vocational as a descriptor of an assessment process with the intent to limit assessment to a specific area (manual dexterity) or skills of an individual? Early efforts (the movement began in the early 1900's) promoted the search for one's true vocation. This focus on individuality was complimented by respect for the occupational multi-potentiality of each individual. The reshaping of our occupational structure during the past few years, however, has greatly eroded the meaning of spiritual calling in the term vocation. A modern secular version is found currently in the American obsession of self-fulfillment. How compatible is this to the philosophy of vocational education, manpower, and realities of life?

We now wonder whether it is possible for all our labor force to find in work a sense of vocation or an avenue to self-fulfillment. Some suggest that the alternatives of work either as vocation, as occupation, or as a kind of undifferentiated employment may be deliberately chosen by an individual as part of his career development. A semantic distinction of interest here concerns the meaning of vocation in Vocational Assessment. The social reformers who generated vocational education movement probably shared the nineteenth century view of vocation as a calling and as a means of self-fulfillment. But vocation in vocational education and in the meaning of vocational assessment has been more narrowly identified in terms of trades. The Smith-Hughes Act officially confirmed this craft orientation. Recent changes in manpower policy, particularly the Vocational Act of 1963, have tended to loosen the definition to include the wide range of occupations requiring various degrees of competencies.



Some individuals involved with establishing and implementing these educational efforts, however, are likely to continue to define vocation in terms of the standards and qualifications of specific occupations. Many teachers, administrators and support personnel are not seriously trying to reconceptualize the mission and content of the educational programs, services and activities for which they are responsible. They have tended in recent years to orient their efforts more broadly to the notion of career and to orient services to career development.

Let's look at the outlook for assessment programs. I believe it goes without much disagreement that if we are to more effectively meet the career development needs of a greater number of individuals, we must somehow provide the resources (expertise, monies, setting) and commitment to assess these needs. We have too frequently implemented educational programs in response to guidelines conceived in federal agencies which may not be appropriate for a specific setting. The challenge is great to educational administrators, directors, coordinators, counselors, and instructional personnel to find more effective ways and more appropriate approaches to facilitate a more productive assessment effort. How can the career development needs of individuals be met if assistance in assessing one's interests, attitudes, and competencies is not available? The question seems not to be one of whether assessment should be viewed as an integral part of the continuous educational process or a specific center approach (three weeks of concentrated assessment experience at the 10th grade), but one of assessment assistance to be assured.

Outlook in terms of need for sound assessment efforts is great. The commitment by all educational agencies appears to be growing. The uncertainty of categorical funding previously available to stimulate development and support assessment efforts necessitates us all to look to other sources of support. This search will test the commitment to these types of services. The efforts such as those in Pottawattamie County and other areas will serve as very valuable benchmarks and examples of why, how, and for whom such services be provided.

I believe we may all agree to a statement that "not enough" vocational assessment has occurred in vocational education. However, efforts to assess and/or evaluate students have increased. The needs of an individual within a specific program population has been a growing concern probably because of the great deal of stimulation provided by federal legislation with increased emphasis on accountability.

Some of the best effort in vocational/career assessment have come from the multi-discipline approaches supported through the leadership of the Special Needs Section and the Guidance Services Section of the Department of Public Instruction. These activities have been administered by the area schools (Iowa Area Community Colleges or vocational-technical schools) either as a part of the student services division or as a special center within the institution's administrative structure. The following institutions have been identified as making considerable contribution in this regard: Indian Hills Community College, Ottumwa; Kirkwood Community College, Cedar Rapids; Hawkeye Tech Institute, Waterloo; and Des Moines Area Community College, Des Moines. The project here in Pottawattamie County and Project Discovery at Red Oak, Iowa, have also been identified as contributing sub-

stantially to the efforts being made in vocational education on an organized special project basis.

Vocational assessment does fit into the funding structure. To be quite candid, it appears that if educational agencies hold a commitment to provide quality education that meets the needs of the youth and adults, it must accept the responsibility for vocational/career assessment. They appear inseparable. The support in resources to assure service or assistance in assessment of need and provision of relevant educational experiences is built into the base support of the institution. The challenge appears to be to obtain the appropriate commitment or resources (expertise, funds, setting) to assure that local millage and general aid serve as base support in this regard. Categorical state and federal dollars have served and indications are that some funds should be available, in fiscal year 1974, to provide support for exemplary, pilot and demonstration activities. Relatively small portions of the monies have gone toward maintaining assessment efforts as an ongoing function of an institution. These exemplary, pilot and demonstration efforts have been administered through the following units within the Iowa Department of Public Instruction: Special Needs Section; Special Education Division; Rehabilitation Education and Services Branch; Guidance Services Section; and Career Education Division.

Leadership and direction should be given to the assessment effort. The best response can only come from those who understand and who are committed to the effort, and who manage resources. Administrative responses may become philosophically laden with platitudes, subject to much review and may fade into oblivion due to a lack of consensus operationally. The responsibility

for leadership and direction may already be fixed in the structure you are now attached. The question may more appropriately be, "Are we all aware of 'who' and 'what' is being done to influence the implementation of the service of assessment?" We in the State educational agency are committed and we will continue to strive to provide leadership and help to provide quality career assessment services for all youth and adults in Iowa. With your commitment and support, we look forward to moving ahead in this very essential component of the educational process.

Jim Athen



## VOCATIONAL ASSESSMENT: WHAT CAN BE GAINED FROM IT?

Donn Brolin  
University of Missouri - Columbia

Paper Presented at the Iowa Invitational Workshop  
On Assessment Systems and Career Development Programs

Council Bluffs, Iowa  
March 26-27 1973

I am very pleased to again have the opportunity to return to Iowa and speak on the subject of vocational evaluation. As most of you know, our current systems of delivery of services to the various types of handicapped persons have really come under considerable fire. At a recent conference on career education for the handicapped in New Orleans, Dr. Edward Martin, Associate Commissioner, Bureau for the Education of the Handicapped, reported that still only one-half of the children needing special education are actually getting it. He indicated further that we have not developed appropriate education at the junior and senior high school levels for our handicapped children. At that same conference, it was indicated that students have to learn about jobs vicariously, that teachers are not prepared well enough to instruct in the vocational area, and they lack adequate materials. Interdisciplinary teams and more help from guidance personnel were indicated to make the student's preparation for life more relevant. At that same conference, New Jersey Senator Williams criticized our delivery of services to handicapped persons even more vociferously. Senator Williams indicated that continuous hearings regarding the Rehabilitation Act of 1972, reveals that rehabilitation services are not doing their job. He indicated that difficult cases were not being served adequately, that many clients

were not being treated well, and that services to the handicapped continued to miss the mark and do not meet the needs of the citizens. His speech proclaimed that we have rejected the rights of handicapped people, that we actually make them more handicapped by virtue of our services, and despite legislation, handicapped children and adults are given only token services. Williams called for providing our handicapped citizens more of an opportunity to achieve their potential.

The Rehabilitation Amendments of 1973 that have finally passed Congress and are now before the President, call for more and better services to more handicapped citizens. The committee criticizing current and past services to our handicapped, reported that many persons are too readily considered to be of terminal employment level, relegated to workshops, and not given the opportunity to progress to a higher level of community employment. Their recommendations attempt to assure these people of getting adequate services so they can reach their maximum level of vocational potential and functioning.

Disenchantment with programs for all kinds of people continues to draw considerable attention throughout the country. I was pleased to learn there are a number of instructors and counselors from correctional institutions at this meeting. These institutions have certainly been the object of many demonstrations and revolts around the country from those claiming many injustices and lack of programs for inmates. Missouri recently had 63 prisoners at one facility bring suit against the Department of Corrections alleging poor treatment, vocational training, etc. On a recent field trip to that facility, I noted that there was only four "counselors" (with limited training) to meet the psycho-social-vocational needs of these individuals.

There are many people in this country who say that education has not done its job. The Pennsylvania decision and those since all assure retarded and other handicapped children that they no longer will be excluded from school because they do not fit into the program. Instead, educational programs must fit the child rather than the child fitting the program as previously. Students, parents, inmates patients, college students, etc., are now demanding their rights and quality services and eventually will get them. Changes in our funding systems are attempting to bring responsibility and accountability to the grass roots level where it should be. Hopefully, this will assure the delivery of the needed services.

The new thrust today is toward Career Education--for all people--and for all periods of life. Career education does not mean vocational education--it means total education for life including preparation for personal, social and economic functioning. For teachers, it means they are going to have to become more aware of the world of work and design their educational efforts so what they teach is directly relevant to career functioning. No longer can we teach primarily academic skills with the anticipation that the student will somehow miraculously assimilate into society, secure satisfactory employment, and live happily ever after. No longer can education pass the buck and expect rehabilitation agencies to pick up the pieces and somehow prepare their students for some kind of job. Now, the responsibility rests with education as well as rehabilitation. If an individual still needs rehabilitation services after terminating his education, the likelihood of eventual success should be greater because that agency should now have an individual to work with who has a higher beginning functional level. No longer may we think only of dishwasher, janitor, salad girl, laundry worker, and the other traditional and restrictive jobs that handicapped students are

placed in. From now on, we must assume more responsibility for developing the potentials of these individuals to their fullest, so we better meet their needs and interests. This is the way I read the current tone of disenchantment with current services and what is going to be demanded. It means that not only do we redirect our own programs but we really initiate truly interdisciplinary cooperation among the helping agencies. I don't mean, for example, merely administrative arrangements between special education and the state vocational rehabilitation agency for OAP (work-study) programs as they are now in most instances being conducted. I mean utilizing the special expertise of personnel within the various agencies so direct client services are delivered to those that need them.

Educational, rehabilitation, and correctional workers must be able to identify and develop the vocational interests and skills of the handicapped as early and accurately as possible. This doesn't occur magically at any one point in time but is a developmental process. Vocational assessment or evaluation, as I prefer to call it, is still a relatively new and emerging art that has a long way to go before it can be considered highly accurate. Currently, the Vocational Evaluation Work Adjustment Association is studying the speciality of vocational evaluation. Sixteen individuals have written position papers on various topics about vocational evaluation, practitioners are not responding to these papers, and a workshop in May will try to pull together the current state of the art in vocational evaluation.

During this workshop, you will have the opportunity to hear specifically about some of the major vocational evaluation systems that have been developed over the past few years. All have potential value for helping to assess the vocational potential of many types of handicapped persons. However, I must stress that none are a panacea or can purport to accurately assess the vocational potential of every type of handicapped person. Therefore, it is very important for you to become knowledgeable about each system so you can make a judgment



about the appropriateness for the people that you work with. It is not my intention to critique any of the systems presented at this workshop because you will be able to do this by listening to the speakers that present each system and by observing the various components of them. Keep in mind that these vocational evaluation systems are a certain aspect of vocational evaluation, that is, each is primarily a work sample system. As I indicated last year, I feel there is much more to vocational evaluation than the administration of work samples. However, each of these systems has been subjected to considerable developmental study and refinement, and those individuals who have developed them should be commended for their fine work.

Let me give you a checklist of considerations that I feel you should make when evaluating whether or not a particular system can meet your student's or client's needs.

1) Does the system take into account expectancy to fail? If your client has had a history of failure, it may be that by this time anything he tries, he expects to fail. Therefore, despite having the potential to perform a certain task this expectancy works against initial performance and he fails. For these individuals, the system should take into account this aspect and provide enough flexibility so that the conditions for failure are minimized.

2) Does the system take into account academic limitations? It is important that a person taking work samples or any other vocational evaluation task is not being unduly penalized because of low academic capabilities. Thus, any task requiring some academic performance should indicate what level is required to do the task satisfactorily.

3) Does the system take into account verbal limitations? Many retarded and culturally disadvantaged individuals are unable to express certain interests and knowledges despite the fact they have them. A system that does not allow or take into account these limitations may be neglecting and not discovering important strengths, weaknesses, and potentials of such individuals.

4) Does the system take into account limited experience? For many handicapped and disadvantaged persons, we cannot assume that they have been exposed to as many life experiences as the typical citizen. For example, certain common objects and places may be totally unfamiliar to these people. Therefore, it is important for the person administering the task to understand the client's experiential level and do the necessary pre-instruction before administering the task.

5) Does the system allow for more than one trial on tasks? Research on learning with the mentally retarded has discovered that frequently these individuals do much poorer on the first attempt but make significantly greater gains during subsequent trials than "normal" persons. This research is extremely important because we may assume too quickly that a previous performance is too low for further consideration on a work activity that actually a client has potential for given enough time.

6) Does the system allow for repeated instruction and check for comprehension? This is particularly important for mentally retarded individuals as well as the emotionally disturbed or culturally deprived. A system that is too rigidly adhered to and lacks flexibility may be totally unfair to its clients.

7) Does the system have face validity? A system that looks interesting and is work-oriented, can be very motivating to its clients. However, many typical nuts and bolts and some mechanically oriented tasks often turn off a great number of people taking them. While these tasks may be very good for some individuals, for others they may be quite detrimental and non-revealing of their potentials and interests.

8) Does the system allow for appropriate conditions for testing i.e., rapport, pleasant surrounding, orderly administration, fatigue? Enough cannot be said about these aspects of any testing situation which can completely invalidate the assessment.

9) Does the system use "spaced" rather than "massed" evaluation? It is better to try to evaluate clients by distributing the various work tasks over a period of time rather than to cram them all in as quickly as possible.

10) Is the system adequately normed on the handicapped and the workers who are doing the various types of tasks and has it conducted further follow-up studies of its vocational prediction validity?

It is difficult for me to feel that there is any vocational assessment system that can accurately predict vocational potential. Vocational potential depends upon so many aspects of one's own personality and also the influence of the family, community, and job site on one's functioning. However, a system that does make legitimate attempts to do the above should be of considerable value in determining an individual's strengths, weaknesses, interests, and vocational potentials.

In addition to the value of vocational assessment alluded to previously, i.e., the assessment of vocational strengths, weaknesses, interests, and potentials, there are several other reasons why vocational evaluation can be extremely beneficial in any educational, rehabilitational, or correctional program. Some of the ones that I would like to list are the following:

1) The student really starts thinking about jobs once he begins taking the vocational assessment battery. Sometimes, talking about jobs stimulates little interest in people and it isn't until they are confronted with an actual or simulated job to do that they really begin thinking seriously about their future and what they would like to do. 2) Job exploration can be initiated by conducting and administering vocational assessments. The student has the opportunity to try out a number of different types of work tasks that are related to a variety of job families which can prompt the student to do further reading on specific jobs related to specific interests. 3) Actual simulations of real jobs can be brought into the classroom, rehabilitation facility, or institutional setting

and tried out without any pressure. As I mentioned, many of our clients have a problem in the area of pressure, and in a more relaxed and non-threatening atmosphere, they can try the various tasks without any undue pressure. 4) Utilizing a vocational assessment system can be a meaningful deviation from the more traditional verbal activities of the classroom. Many handicapped people, particularly the retarded and disadvantaged are more likely to enjoy and to be successful in more manipulative tasks and activities than the verbal ones that they encounter in a classroom situation. 5) A vocational assessment system can act as a motivator to learn more academic material so they will qualify for specific jobs they are interested in. Too many times, former students regret not learning certain academic material while they were in school because such deficiency is now precluding any chances for the kind of work they would really like to do. 6) The vocational assessment system allows a method of comparing student abilities with those on actual jobs. Many times the teacher, evaluator, or vocational instructor are surprised how well a client is able to perform certain tasks/jobs that people are actually doing. 7) Vocational assessment measures can be used as behavioral change instruments. For example, work habits, interpersonal relationships, cooperation, and other behaviors that are required to satisfactorily perform different jobs may change when one is engaged in vocational assessment activities requiring these behaviors. 8) As an indicator of specific vocational strengths and weaknesses, the school will still be able to develop such strengths and work on such weaknesses while the student is still there rather than finding out these problems near the end or after the program. This again can make the school program more meaningful and individualized for each particular student. 9) Vocational assessment brings reality into the classroom and gives the student a reason for learning materials. He is able to see when confronted with actual vocational tasks why he has to be able to read,

write, compute, be aware of his surroundings, and appropriately relate to other individuals. 10) Vocational assessment tasks can be a builder of self-confidence and a different technique of learning. As mentioned earlier, the more verbal and abstract classroom material is, often very frustrating and self-debilitating to many handicapped individuals whereas perceptual-motor activities may often be much more appropriate. In fact, there is evidence that the skills required in school are different to those needed for satisfactory community adjustment, i.e., the same skills needed for academic success are not directly related to community success.

None of us have really done enough to assure the successful adjustment of the handicapped person into our complex society. If we think we have, we're kidding ourselves. Our services to these people have been desultory, and no one really seems to know what the other person is doing for the individual, just what he thinks they're doing. I am currently doing an extensive study of former special education students, their parents, employers, and various types of school personnel in a large Mid-Western city. Although I have not yet completely analyzed the results, preliminary inspection of the data appears to indicate that most of these 18-23 year old former special needs students are not adjusting satisfactorily to society and that they are not learning many of the skills felt necessary to learn in a high school program. Let's not have illusory ideas that we are doing all that is needed for our handicapped citizens. They need much more than we're currently giving them.

If we are really concerned about our handicapped citizen, then many of our past failures can be minimized in the future by initiating a meaningful vocational assessment program to complement the fine accomplishments we have made in the academic and psycho-social development areas. Then we will really begin to meet the career education needs the handicapped so richly deserve to have met.

Assessment Systems  
in  
Career Development Programs

Dennis J. Dunn  
Research and Training Center  
Department of Rehabilitation and Manpower Services  
University of Wisconsin - Stout

Presented at the Iowa Invitational Workshop  
on Assessment Systems in Career Development Programs

Council Bluffs, Iowa  
March 26-27, 1973

Career education and vocational evaluation are two very "in" but "fuzzy" concepts. They are concepts we can certainly agree with up to the time we try to put them into operational practice. Then, if we look at a program and ask the program operators what they are doing, why they are doing it, and what they expect to accomplish by doing it, we encounter a bank of semantic fog that clearly indicates that we really don't know much about either career development or vocational evaluation. We have some technologies available to us, but the linkages required to form these technologies into an operational system are lacking.

In this presentation I would like to discuss career development, the role of vocational assessment in career development, and the application of commercially based assessment systems within career education programs. As I go through this presentation, I hope to be able to establish some linkages between our current state of theory and our current technologies.

Career Development and Career Education

Career development, as I understand it, is a lifelong developmental process which closely ties in with what has been called developmental counsel-

ing. When we consider the ramifications of our careers on our total life styles, the importance of career becomes obvious. Our status in the community is based largely upon our occupations; our income from the job we hold places constraints on many of our activities; the satisfaction we have with our job can affect our family lives; who we work with influences who we have for friends. Yet, if we stop to take stock of ourselves for a moment, and if we ask ourselves one question: "How did I get here?" we come up with an interesting finding. All of us are in this room, but I doubt that we could find many common elements in the sequence of events that brought us here. Instead we find a sequence of decisions and choices, some major, some minor, that brought us here. Some of these decisions were strongly influenced by chance or circumstances existing at a moment of time; others were the culmination of a planned set of activities. But all of these decisions and choices had an effect upon our careers and on our being here. If we look into the future, we will be making other choices and decisions that will influence our careers. Some of us may decide to take an advanced degree; others to take a certain civil service exam; others to have a child.

Career development is something that extends over a lifetime and, most importantly, is a reflection of a series of choices and decisions we have made. At one level, decision making becomes the crucial dimension of career development. This is essentially the position taken by Tiedeman (1963) and Kroll, et al (1970). Once we begin to consider the ingredients of a decision, particularly a vocational decision, we find that this is actually a rather broad approach that includes such things as self concept, need states, and other types of information.

Clarke, et al (1965) have stated that there are two requirements for "good" decision making: (1) The person needs adequate information and (2) the

person needs a strategy for processing the information to arrive at a decision. It is my contention that career development essentially involves the person in a series of decisions in which he uses information about himself and information about occupations and processes this information according to a set strategy to arrive at a choice. His "career development" summarizes the choices he has made.

It is not my purpose to describe the career development process in any depth or to engage in a technical discussion of decision making in career development. If you care to go into this in more detail I would suggest reading a recent book by Kroll, et al (1970) who present a reasonably good discussion of these subjects. The point I would like to make is that when we talk about career education as something that ties into lifelong career development, we are basically talking about training a student to acquire information and to process that information to arrive at a valid choice. If we can accomplish those two goals, then we have provided the student with a generalizable skill that can be utilized throughout his entire life span.

You will note that I said we should train the student to acquire information. One of the biggest shortcomings of current career education programs is that they are primarily occupational information programs that provide the student with information. This may be adequate during the school years, but it is inadequate over the long run. The way the labor market is changing, the way jobs are changing, and the way careers are changing, we will have to produce students who have the capacity to deal with vocational crisis and make transitions into new careers (Adelson, 1970). Essentially career education becomes a means of teaching a student an approach to these future problems by focusing upon decision making.



This will be a more difficult task than it seems since most of us really don't know how to handle these career problems. We have a substantial number of unemployed teachers floundering around who are unable to select alternative careers. More dramatically, the recent collapse of the labor market in the aerospace industry confronted a substantial number of highly skilled people with a vocational crisis. An emergency federal program had to be instituted to assist them.

I have referred to the two major requirements for good decision making, information and strategy. In the remainder of my discussion I will focus primarily upon the information component, and particularly upon the role of vocational evaluation in career education programs.

#### Vocational Assessment in Career Education

By the time a student reaches the secondary level he is required to make increasingly more specific career decisions. For example, he may be required to select a high school curriculum track or he may be required to select certain courses for his curriculum. To make informed choices such as these, the student already must have reached a point in his career development where he has made some broad, but tentative career choices. Students generally have reached this point by the early high school year and are able to make adequate choices.

It is important to recognize that the type of information required for these decisions is broader than merely information about jobs, occupations, or courses. The student also has to have information about himself. Typically this information comes from two sources: his previous experiences and what we have told him about himself. This latter information can derive from course grades and standardized tests.

The special needs student population presents some problems in a model of this sort. First of all, they generally do poorly on standardized tests. Secondly, we tend to discount their self evaluative statements since they are based on experiences that are different from those of other students. Closely related to these is a third problem of providing additional information to the student. As decisions become more specific, increasingly more information is needed by the decision maker. Much of this information can be provided in written, spoken, or media form to the normal school population. However, as Reissman has noted, the special needs population includes a substantial number of individuals who acquire information through the kinesthetic channel -- via direct, hands-on experiences. (I should note that although this causes problems in the auditory and visual world of the school, the openness to direct bodily experiences is an advantage in later vocational life and is something that other students have to acquire.)

Basically we need a component within the career education program that does at least three things: (1) provides us with vocationally relevant information about the student; (2) provides the student with a set of experiences comparable to those of other students; (3) provides the student with a means of acquiring information about himself via direct, hands-on experience. A component that does these things may suffice to meet the immediate, in-school problems of the special needs population. However, if we consider the life span approach to career education, the problem of decision strategies emerges. Specifically, an effective strategy for choice involves examining the short and long run consequences of a choice. An appropriate educational goal would be: (4) provides a situation in which the student can learn to test out the consequences of a choice. And if we reflect back to the need of the "normal"

student to learn to acquire information through direct experience, we can establish a fifth objective for this career education component: (5) provides a situation in which the student can learn to evaluate himself on the basis of direct experience. These five objectives delimit an assessment component within a career education program that will provide information for school personnel and, more importantly, provide both a self assessment and learning situation for the student.

Vocational evaluation using a work sample approach is a technology that can be used to attain these five goals in career education programs. Specifically, work sample vocational evaluation programming can function as follows:

- (1) through observation of student performance and behavior on a series of work samples a trained vocational evaluator can assess vocationally relevant variables including abilities, interests, temperaments, and physical capacities.
- (2) by establishing a core set of work samples, representative of a wide range of occupational areas and job requirements, the evaluator can expose students to a comparable set of vocationally relevant experiences.
- (3) work samples provide a direct, hands-on experience for the student during which he can experience and feel what it is like to perform specific work tasks and to acquire information about his reactions to performing these tasks.
- (4) by providing the student with the opportunity to choose those work samples he would like to perform, the vocational evaluator provides a situation in which the consequences of a vocational choice become immediately known to the student.

(5) by providing the student with an opportunity to indicate his reactions to his performance and behavior on work samples and following this up with a statement of performance and behavior as seen by the evaluator, a learning situation for developing self evaluation abilities is established.

The use of a work sample based vocational evaluation program can attain these objectives within a career education program. In other words, the assessment component can extend beyond the obtaining of data about the student and into the realm of providing the student with a learning situation in which he acquires basic skills that will facilitate vocational decision making in the future.

I could go on to discuss some of the additional implications of vocational evaluation techniques in career education programs. However, I think some of the time available to me would be best spend discussing some of the traps people fall into in implementing vocational evaluation programs. Hopefully, by being aware of some of these traps, you will be able to avoid them.

The first trap is program planning and budgeting. Vocational evaluation is one of the most expensive services that can be provided. A program such as that I described above is very expensive: the cheapest program that I could develop would handle about 180 students per year at a cost of \$250 per student. Very frequently during the planning phase of the program the mistake is made of determining the need for the program on the basis of an existing backlog of students who could benefit from it. This produces a misleading figure. A more accurate figure is based on the projected rate at which new eligibles will be entering the system in the future. This provides a better estimate of whether there will be a sufficient number of

new cases to justify operational costs. By the same token, the annual operating budget has to provide a healthy amount for maintenance of work samples. In a work sample system you are using the same equipment over and over and it is being used by inexperienced students. This leads to equipment breakdown and failure. Materials are being consumed and must be replaced. These equipment and material costs have to be included in the budget and added to the expense of operating a program.

Trap number two relates to the program planning trap. Basically, trap two involves establishing a program with too narrow a focus. Vocational evaluation is often regarded strictly as a substitute for psychometric testing with handicapped and disadvantaged groups. I indicated earlier that we can conceptualize vocational evaluation as assisting us to attain five career education objectives. Only one of these objectives refers to the psychometric issue; the remaining four relate to what the student can derive from evaluation. Rather than narrowly focusing upon ourselves and how we can benefit, we should consider how students can benefit from evaluation. Once we take this point of view, vocational evaluation becomes an extension of our career education teaching component. It is applicable to a wider range of students, including the so-called "normal" student.

Program trap number three is the failure to provide for the implementation of the findings of the vocational evaluation program. Vocational evaluation has tremendous implications for student curriculum planning. As the student experiences different occupations and jobs and comes to select future vocational goals, he also is able to determine the relevance of his academic coursework to attaining future goals. The student may, for example, discover that he is interested in, and has the abilities for, work as a machinist.

At the same time, since he has actually performed work tasks from this occupation, he becomes aware of the fact that he needs math skills to be successful as a machinist. Our experience at Stout with evaluation programs for secondary school students has indicated that such a student is likely to show improvement in his academic coursework, provided that the school makes changes in the student's curriculum to include vocationally relevant courses.

There are two barriers to implementation of findings. The first barrier to implementation is that vocational evaluation reports often do not contain the information necessary to translate recommendations into action. An evaluation report has to communicate and, in order to communicate, it has to be written from the frame of reference of report consumer -- the person who has the responsibility for translating recommendations into action. Vocational evaluators frequently ask the question "How do you write good reports?" The best way to answer this question is to ask the consumer what information he needs to implement the findings of evaluation. The report then becomes a medium for communicating this information.

The second barrier to implementation is a failure to adequately prepare teachers and other school personnel for change. I have mentioned that vocational evaluation has tremendous implications for curriculum development and change. Yet change, by its very nature, is threatening. It is one thing to talk of individualized instruction and meeting the individual needs of students: it is another thing to actually implement this programming. I have been greatly encouraged by the fact that schools can be extremely flexible in academic programming and accommodating to individual student needs. However this requires an extensive amount of in-service training and individual conferences and staffings to achieve. In other words, the staff

of the evaluation program have to be able to reach back into the school if the program is to be successful. They cannot be confined to a simple assessment and report writing role.

The fourth trap in evaluation programming is a failure to hire adequately trained vocational evaluation personnel. Once we begin to think in terms of the kind of career education vocational evaluation program I have outlined here, we have to give consideration to securing adequate staff. At this stage of development of vocational evaluation we have some sophisticated technology, but this technology is still only as good as the person using it. Trained and experienced vocational evaluators are in short supply and this manpower shortage will continue to persist, if not worsen, over the next several years. Yet we see school systems impose artificial hiring barriers, such as requiring the evaluator to be teacher certified, that further restrict their potential manpower supply.

The fifth and last trap I will mention is the trap of not making adequate use of existing knowledge in vocational evaluation. It may seem to many of you that the things we are talking about are new and innovative. In fact they are not. The use of work samples dates back to the early years of the century and, from a technical point of view, work samples haven't changed much since the first world war (Chapman, 1921). My own experience with vocational evaluation programming with secondary school students goes back over a decade. We are currently seeing a resurgence of interest and the development of better service delivery models. However, we are indeed foolish if we ignore the experience and expertise of persons in the field of vocational evaluation by applying the illusion that we are "doing something new."

Commercially Available Work Sample Systems  
in Career Education Assessment Programs

The failure to make use of existing expertise I just mentioned extends to the technology of work sample evaluation. There currently are three major work sample systems available for purchase: the Jewish Employment and Vocational Service (JEVS) work samples, the TOWER system, and the SINGER/Graflex vocational evaluation system. I have elsewhere compared these three systems on certain technical features (Dunn, 1972). Here I would like to make some other comments regarding the use of commercial systems in vocational assessment programs.

The commercially available work sample systems have numerous advantages, particularly for a new vocational evaluation program. Not the least of these advantages is that the developmental work has already been done for you. The work samples have been developed, field tested, de-bugged, and norms and scoring procedures have been established. Although the price of these systems may seem to be high, a recently completed study by the Research and Training Center at Stout suggests that it could cost you two to four times more to develop your own work sample evaluation system than what you would pay for a commercial system (Dunn, 1973).

The question that comes up over and over is "which system should we buy?" The point to keep in mind is that the three systems are complementary, not mutually exclusive. Each system is best suited to attain certain goals. SINGER/Graflex is basically a vocational exploration system. TOWER is oriented toward vocational training areas. JEVS assists in assessing the level of vocational functioning of the student. Each of these goals is dis-



inct and may be appropriate at a different phase of a career education program. The decision as to which system or systems to purchase has to be a function of your specific goals and objectives for the vocational evaluation program. I can see a role for all three systems.

It is easy to allow yourself to get distracted by extraneous factors and claims made for a system. For example, the SINGER/Graflex system has a slick package and certainly looks impressive. The JEVS system does not present this initial impact of sophistication. Experience with a system quickly reveals however, that what a system looks like doesn't have much relationship to what it does. The packaging of a system can actually interfere with operation. SINGER/Graflex is particularly vulnerable to this. The carrels look nice, but you find that you can't make very effective behavior observations of the student at work. The carrels also present problems from a human factors engineering point of view (Munn, 1972). The Study-Mate used to present the instructions is a good, durable machine for educational applications, but it is prone to frequent breakdowns when subjected to the hard usage of vocational evaluation settings. The other systems have their particular problems too.

One problem that particularly exists with the JEVS system is the tendency of evaluators to alter the sequence of administering the 28 work samples or to delete some of the work samples from the battery. Once you become familiar with the JEVS system you discover that, although it doesn't look very impressive on the surface, it is actually the most intricate, subtle, and sophisticated of the work sample systems. Altering the sequence of delivery of certain work samples, or failing to administer particular work samples, can alter the level of difficulty of other work samples and also

result in a significant information loss. Because the JEVS system uses a graded series of work samples, you need the information from the lower level work samples to draw accurate conclusions from higher level work samples. This subtlety is often overlooked.

As a general rule, a commercial work sample system shouldn't be modified without good cause and without a careful examination of the consequences of the modification. A minor change in instructions breaks the standardization of the system. The difficulty level of the task is altered and the norms are invalidated. Similarly, the use of materials and tools other than those specified by the system has effects on the validity of obtained results.

A major limitation of any of the work sample systems is that they are not completely comprehensive or totally applicable within a particular geographical locale or school system. Consequently, consideration will ultimately be given to the development of additional work samples to fill in the gaps in the assessment program. One of the distinct advantages of the commercial systems is that they provide a foundation and model for additional work sample development. Knowledge of the basic structure and organization of any of the systems provides a good basis for the evaluator to determine the additional work samples needed and to secure the information necessary for work sample construction.

To summarize, the commercial systems save time and money during the initial establishment phase of the evaluation program. From this point of view they are a wise investment. Similarly, they provide the evaluation program with a foundation and structure for additional work sample development. It should be recognized, however, that there are some limitations with the currently available systems. No one system will do everything for you and you have to think in terms of how a particular system will assist

you in attaining your career education goals. It is easy to be misled on this point and to believe that a single system is the answer to all of your problems. Finally, there is one point to be stressed again: a vocational evaluation program, even one that uses commercial systems, is still only as good as the person operating it. The commercial systems are tools of the evaluator. Unless the evaluator knows how to use these tools, and to combine them with some of the other tools at his disposal, the system and the evaluation program is wasted.

Dennis J. Dunn



## References

- Adelson, M., Manpower, adjustment, and the system. Santa Monica, Calif.: System Development Corp., 1970.
- Chapman, J. Trade tests: The scientific measurement of trade proficiency. New York: Henry Holt and Company, 1921.
- Clarke, R., Gelatt, H., and Levine, L., A decision making paradigm for local guidance research. Personnel and Guidance Journal, 1965, 44, 40-51.
- Dunn, D., Work sample summary chart. In Backer, T., Methods of assessing the disadvantaged in manpower programs: A review and analysis. Los Angeles: Human Interaction Research Institute 1972.
- Dunn, D., Estimating work sample development costs. Consumer Brief, 1973, 1, 1-3.
- Kroll, A., Dinklage, L. Lee, J., Morley, E., & Wilson, E. Career development: Growth and Crisis. New York: John Wiley & Sons, 1970.
- Munn, C. A human factors checklist for vocational evaluators. Menomonie, Wis.: Research and Training Center, University of Wisconsin - Stout, 1972.

## The Singer Graflex System

Stanley Hienemann, Consultant  
Graflex Education & Training Division  
3750 Monroe Avenue  
Rochester, New York 14603

Presented at the Iowa Invitational Workshop  
On Assessment Systems and Career Development Programs

Council Bluffs, Iowa  
March 26-27, 1973

The Singer Graflex System consists of ten work stations outfitted with a variety of industrial tools. The ten stations are:

1. Basic Tools
2. Bench Assembly
3. Drafting
4. Electrical Wiring
5. Plumbing & Pipe Fitting
6. Carpentry & Woodworking
7. Refrigeration, Heating and Air Conditioning
8. Soldering and Welding
9. Office and Sales Clerks
10. Needle Trades

An evaluator manual and evaluation forms are included which cover the procedures for using the system. In addition, an instructional filmstrip with a sound cartridge accompanies each work station.

Each work station (36" w x 36" d x 19" h) is self-contained and is designed either to be self-standing (it has extension legs) or to sit on a desk top. For security and storage each work station can be completely enclosed and locked through the use of sliding panels inserted along rails bordering the exposed top and front of the work station.

Each work station is outfitted with tools appropriate to the work station function. In addition, an initial supply of consumable materials used in the work tasks is provided. The work station also has a Graflex Auto-Vance Study Mate rear screen sound/filmstrip projector mounted on the rear panel along with a remote control box for trainee operation.

The work station can be moved to different locations. Therefore, arrangement of the portable work stations is flexible and a variety of physical set ups can be accommodated.

The manual describes the background and purpose; the system and its components; and gives directions for utilizing the Graflex Vocational Evaluation System.

Appropriate evaluation forms are provided in the manual. In addition, an initial supply of forms are provided by Graflex as part of the system.

The manual takes the evaluator through the program step-by-step, giving the suggested sequence of events and information on how to achieve most effective use of the system.

Basically, the process involves:

1. Orientation to the program

2. Work Station I

(a) Audiovisual (AV) Presentation of:

1. How to operate machine
2. Jobs related to that work station

(b) Trainee rates interest based on AV description

(c) Work Station tasks directed by AV presentation

(d) Trainee rates interest based on work experience

(e) Trainee rates own performance of tasks

(f) Evaluator rates trainee performance

3. Repeat for other work stations
4. Trainee rates interest by pictures of jobs
5. Evaluator tabulates total interest
6. Evaluator brings together all available data to rate interest and performance and makes recommendations

The manual also contains inventory control lists of tools and materials supplied as part of the Graflex Vocational Evaluation System. Each item is described and its quantity specified.

Each station has its own filmstrip and tape cartridge for use by the trainee. These are placed in the Graflex Auto-Vance Study Mate mounted on the back of the work station. The trainee controls the presentation via a remote control switch mounted on the right-front part of the work station. Trainee control is necessary for self-pacing.

Problems presented by diverse reading levels are avoided. The programmed instructions allow the system to be used by illiterate participants with a minimum of evaluator assistance.

The audiovisual presentation:

1. Introduces the trainee to the tools of that work station and tells him how to use them.
2. Describes a series of actual jobs related to the activities he will carry out at that work station.
3. Instructs the student step-by-step through the work station tasks which have been designed to replicate facets of jobs as found in an industrial setting.

The Graflex Vocational Evaluation program is oriented to self-study. There are no rigid time limits. Usually, however, the screening program can be completed in seven days. Both the trainee and evaluator participate in the assessment. Trainee evaluation of his own interests and aptitudes is

combined with the instructor's assessment to form a definitive picture of job training direction most suitable for each client.

The program engages the trainee in goal-directed work following a brief orientation. The evaluator observes the trainee's behavior in a variety of work tasks developed from descriptions found in the Dictionary of Occupational Titles. The unique feature of the system is the occupational exploration segment which helps the trainee determine interests by describing through audiovisual techniques a number of actual jobs related to the work stations.

The Graflex Vocational Evaluation System is a direct result of Graflex' experience in training disadvantaged clients in a variety of programs:

Job Corps Centers

Vocational Rehabilitation Training Centers

Correctional Programs

NABS/JOBS Programs

The Graflex Training Division offers a full line of services, curriculum materials, equipment, and management expertise for manpower development programs.

A price-purchase breakdown is shown below.

SYSTEM PRICING  
THE SINGER VOCATIONAL EVALUATION SYSTEM

<u>PRODUCT #</u>	<u>ITEM</u>	<u>PRICE RANGE</u>
-	THE SINGER VOCATIONAL EVALUATION SYSTEM - COMPLETE WITH EVALUATORS' PACKAGE, AND ANY TEN (10) WORK-STATIONS, SELECTED FROM THE LIST	From \$8,666.00 to \$10,344.00
-	INSTALLATION/ORIENTATION -2-DAY PROGRAM (CONDUCTED BY SINGER/ GRAFLEX PERSONNEL)	200.00 - 200.00



<u>PRODUCT</u>	<u>ITEM</u>	<u>PRICE RANGE</u>
-	SHIPPING CHARGES - FROM MORTON GROVE, ILLINOIS TO DESTINATION (ESTIMATED & INVOICED)	<u>XXX.XX</u> - <u>XXX.XX</u>
-	TOTAL PRICE (PLUS SHIPPING):	From \$8,866.00 to \$10,544.00

=====

PRICE (PER UNIT), FOR SUPPLEMENTAL & ADJUNCTIVE WORK STATIONS

52-101	1. Basic Tools	\$ 872.00
52-102	2. Bench Assembly	1,112.00
52-103	3. Drafting	849.00
52-104	4. Electrical Wiring	805.00
52-105	5. Plumbing & Pipe Fitting	947.00
52-106	6. Carpentry & Woodworking	916.00
52-107	7. Refrigeration, Heating & Air Conditioning	791.00
52-108	8. Soldering & Welding	818.00
52-109	9. Office & Sales Clerk	850.00
52-110	10. Needle Trades	907.00
52-111	11. Masonry	853.00
52-112	12. Sheet Metal Working	1,490.00
52-113	13. Cooking & Baking	1,490.00
52-900	• - Evaluator Package	58.00
-	- Installation/Orientation - 2-Day Program (Conducted by Singer/Graflex Personnel)	200.00
-	- Shipping (Estimated & Invoiced)	XXX.XX

\* Prices apply to purchases of ten (10) or more work-stations only.  
 \*\* optional items required with all System purchases.

Selecting of any ten (10) different of the above thirteen (13) work stations, plus the Evaluator Package and the Installation/Orientation Program, will provide a complete Singer Vocational Evaluation System within a 2 1/2 year period.

(Less than \$5,000 (plus shipping charges)  
 or less than \$10,000 (plus shipping charges)

The Singer Graflex System is applicable in:

- a. Vocational Rehabilitation Centers
- b. Vocational/Technical Schools
- c. NABS/JOBS Programs
- d. Manpower Development & Training Centers
- e. Correctional Programs
- f. Business and Industry Training Programs
- g. Labor Union Training Programs Job Corps Centers
- h. Community Training Programs

The Graflex Education and Training Division will work with any organization to tailor the Vocational Evaluation System to the customer's requirements and smoothly integrate it into existing programs. They will also work to develop individual stations or an entire system to meet particular requirements.

WATER - PAUVALUATION

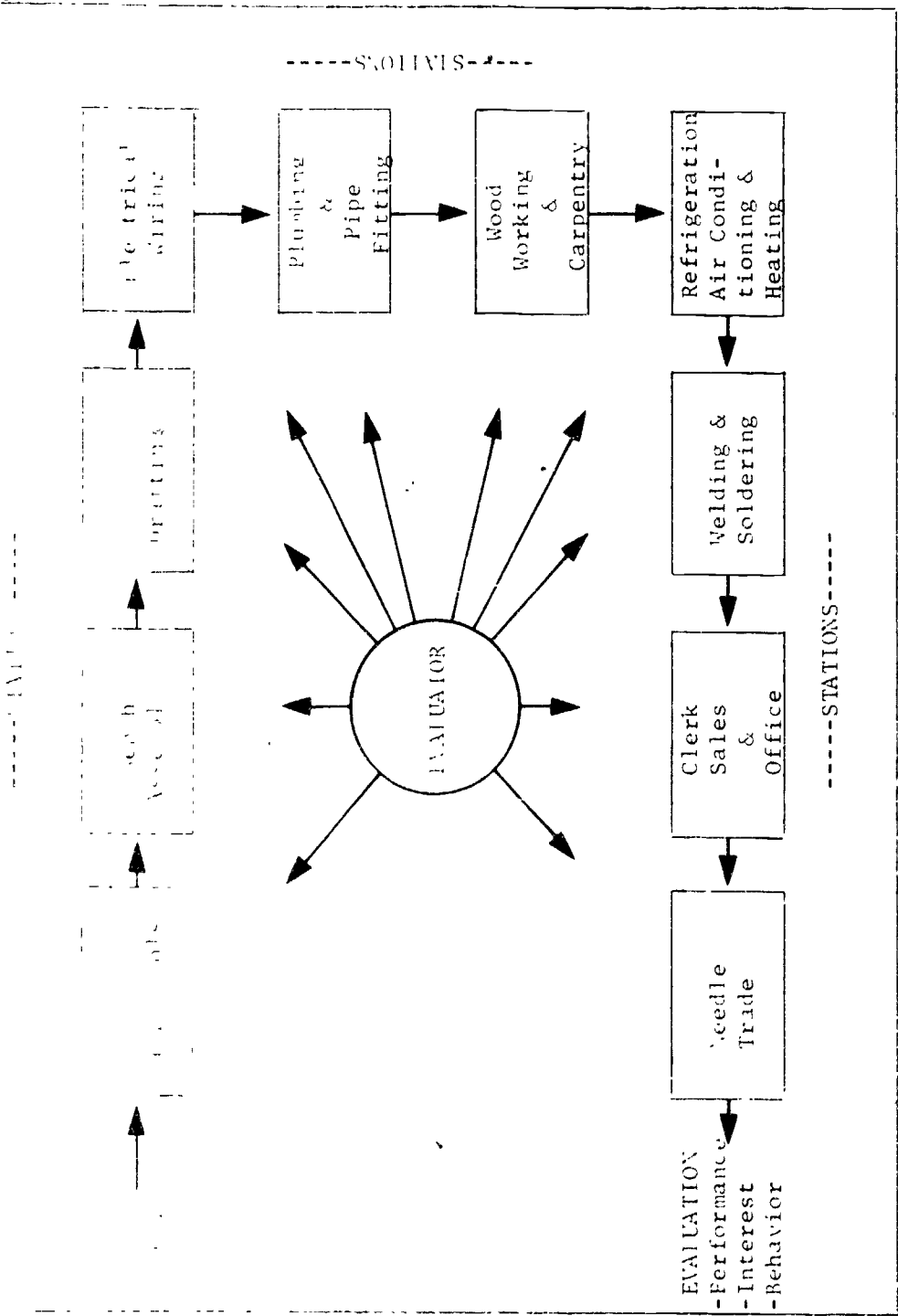

USE OF THE SINGER SYSTEM FOR CAREER EXPLORATION

Donald J. Andersen  
Counselor  
Hawkeye Institute of Technology-Waterloo

and

Bruce Stoll  
Special Needs Coordinator  
Hawkeye Institute of Technology-Waterloo

Paper Presented at the Iowa Invitational Workshop  
On Assessment Systems and Career Development Programs

Council Bluffs, Iowa  
March 26-27, 1973

Vocational Technical Education has for sometime tried to identify a means to predict student's probably success in programs. The majority of the instruments on the market are designed for the Academic Area. They measure Intelligence, Aptitudes, Personality, Interests, and so forth, but these are not totally relevant to our purpose. Motivation, dexterity, and ability to follow directions are far more important.

We wanted to see people do things with their minds and their hands. We wanted them to be able to project these activities into Career Choices or Educational Plans. We wanted an evaluation of something other than verbal behavior. We wanted to see how people behave under different circumstances. We wanted an opportunity to discuss Career Plans in a relaxed atmosphere. The Singer Graflex Evaluation System provided many of these things.

We have used it in a slightly different way than it's intended purpose. The skill evaluation for each station has been secondary. The psychological

evaluations of how a person operates, perceives him or herself, and relates to the variety of tasks is primary. You might say the knowledge of Self has taken precedence over all else.

Hands-on experiences on the Singer are the Key to its success. Everyone likes to be involved with something. The exposure to a variety of occupational clusters gives insight into many things. The individual assesses himself in terms of:

1. Do I like it?
2. Can I learn it?
3. Is it something I would like to do for an extended period of time?

These are the types of questions we hoped individuals would answer for themselves. We felt the Singer System would assist in this decision-making process.

We have used the Singer System with a variety of people. It serves different purposes for each group. I will briefly discuss specific observations on each population -

- A. Adult Women
  - B. Youth (Boys and Girls) 7th Grades
  - C. Pre-Career Students
  - D. Drop-outs from Jr. High & Secondary Systems
  - E. Handicapped
  - F. Minorities (Black)
  - G. Adult Men (other than Minorities)
- A. ADULT WOMEN - The biggest value is the opportunity for them to discover non-traditional areas of training and employment. Most Adult Women perceive themselves in traditional roles. The experiences with

Woodworking, Wiring, Drafting, Soldering, Etc. and success in these areas stimulates thinking and opens a multitude of possibilities for them.

- B. YOUTHS (BOYS & GIRLS) (7th Graders) - We had excellent success with this age group. The exploratory phase of Career Development is extremely important for them. It gives relevance to the next 4 years of school, a tentative direction can be established. Here again the girls receive exposure to non-traditional Career Areas. There was a surprising contrast between their behavior at the station and their behavior in a Public Educational environment.
- C. PRE-CAREER STUDENTS - Although A-G are all pre-career, there is a group of 18-20 year olds, who are a little unique. The Singer coupled with local business exposures provide a variety of information. This group needs specific experiences relevant to where they are and where they want to go. Extensive career counseling is involved with this group.
- D. DROP-OUTS (JR. & SR. HIGH) - We must accept that not all youths will complete 12 years of traditional education. Therefore, it is important to provide career direction and subsequent training prior to age 18. We operate an alternative school for this population. A part of this schooling requires exposure to the Singer. As a result many individuals have experienced success in something for the first time. It has let them view the Why's of Academic Education relevant to a particular career choice. They identify areas of interest through the use of extensive supplementary materials and proceed towards realistic goals.
- E. HANDICAPPED - Depending on the particular case, the Singer has been extremely effective. The basic tasks worked on, allow the individual success in career clusters with which they are completely unfamiliar.

It provides the evaluator an opportunity to evaluate physical and mental limitations, and to provide counseling towards realistic areas.

Vocational Rehabilitation has found this a good tool for their clients.

- F. MINORITIES (BLACK) - Exposure to areas of career choices is particularly good. We have discovered that most Minority individuals are culturally deprived when it comes to basic usage and identification of tools. The Singer Program allows this needed experience to proceed at the individuals own pace. The supplemental career materials and exposure to training programs and jobs makes this a meaningful experience.
- G. ADULT MALES (Other than Minority) - Most in this group have had at least limited exposure to many of these areas. Their initial approach is that it is menial and ridiculous: "Kids Stuff." However, they do respond with considerable counseling and explanations of purpose. The ability to follow specific instructions and the subjective evaluations obtained by the evaluator are valuable. They usually reverse the normal sequence by forcing the adult male to make some kind of choice before going through the stations.

We have found the Singer Graflex Evaluation System extremely valuable in Career Exploration and interest identification. This was our intent and it has for the most part lived up to our expectations. We have discovered through it's usage that some areas are not covered or are not realistic enough. The biggest need is the development of a work station in mechanics. Although there is some transfer of knowledge through the use of various tools, the element of Mechanical Reasoning does not exist. In addition to mechanics, we need something in Health Occupations, Electronics, Animal and Plant Management and some way to

get at the abstraction of many other Technical fields. We have also discovered the depth and focus of some curricula is rather shallow. Fortunately we have at our disposal, 31 Career Vocational Technical programs to expand exploration activities. We are using 8mm cassettes with tapes to further explore additional and more specific areas.

One example of unrealistic exposure would be the Welding Station. It is not realistic to simulate welding with a butane torch in a well lighted, air-conditioned building. Generally, if this is a high interest area for the individual, we will provide him with an actual experience in our welding career program for a short period of time. In addition, he will view several films describing M.I.G. and T.I.G. welding. He will also be exposed to the V.I.E.W. System which has Micro-film cards detailing local information regarding employment outlook, requirements, good and bad points, average wages, and where more information can be obtained. This combination of experiences broadens the individual's outlook and provides adequate information to form realistic career plans.

Administration or Supervision of the System is relatively simple. We would recommend that the evaluator be trained in Counseling. He or she should also know or be able to learn, the workings of all the stations. This means proper use of all tools and equipment. The Evaluator should be a warm, empathetic, understanding person able to relate to all people. Students, especially, need reinforcement in their pursuit of a career. This reinforcement needs to be well planned (Refer to counseling feedback I and II).

The number of people worked with at any one time should not exceed (7). This is particularly true if there are time periods in between their completion of the station. In our case, we have between 30 and 40 people



working at various times. Any more than 7 would mean some major scheduling problems.

The problems with running stations full is the varied times that the individuals require the evaluator. There are times with 7 stations going that (2) people are waiting or needing assistance.

The equipment involved is basically good. The tools for the most part are Sears Craftsmen and if they break, they are replaced at no charge. The Study Mate machine's major problem is the light bulbs. It is best to have (1) dozen bulbs on hand because of their short life. We have experienced some problems with the Audio and a few with the Inaudible signal. The controls (on-off) may cause problems, and if the switch breaks it is best to replace it with a toggle switch.

Materials are best purchased locally. We have established supply sources in the Community for all materials. An example of local savings is the Credit Sales Tickets for the Office & Sales Clerk Station. Singer gets \$100.00/1000. You can buy Master Charge tickets from your local bank at \$12.00/1000. Another example would be the Drafting Vellum. Singer price is 100 sheets for \$15.00. Our local price is \$6.25. The pine, plywood and dowels for 100 people by Singer costs (\$201.40). Our local cost is \$26.84. We must admit difficulty in understanding the reasoning by Singer in their pricing of materials and supplies. As owners of a \$9,000.00 System, we feel that more competitive prices would be in order.

## Counseling Feedback: I

Pam:

You are a very charming and interesting young woman. You are the type of person people like to be around and do things with. You are polite, usually enthusiastic, interested in people. You are much more capable than you think you are.

Although your central interest is now in nursing, your secondary interest in clerical is no less significant, for many of the tasks of a nurse are clerical in nature--making reports, keeping patients charts up to date, etc. Pam, I think you would make an exceptional nurse. In fact, I think you would be effective in any occupation dealing with people.

Although you are really interested in only three of the tasks you got into at Hawkeye, you performed very well at all of the stations. You are very good with tools. That is important in nursing--especially if you become a surgical assistant. You are very precise and exact--another important quality. You are patient and persistent--no less important. You are very neat and clean. You get along very well with people. Take algebra and chemistry in school, Pam, even if you may have to study very hard. Home economics would also be a beneficial subject.

Pam, I am going to be very honest with you. I don't think you are as confident as you are entitled to be. I don't know why. Perhaps people have been too critical of you, failed to give you the encouragement you need--encouragement every young person needs. Because you lack self-confidence you hold back, are reluctant to really get involved in things. And because you hesitate or don't get-with the things you do, you don't do as well as

you could. And confidence comes from being successful. It's kind of circular, as you can see.

To start with, pick one subject and really get into it. You will have to make the first step and then the people you work with will start encouraging you to go further, "get into it" even more. Don't hesitate to ask your parents and teachers to help you. Talk all this over with some adult you get along well with. You have plenty of natural ability. You're going to have to learn not to be afraid to use it, test it, develop it. Don't be quite so cautious, open up, become more aggressive and daring. If you hold back you don't run as much risk of failing but you lose a lot of opportunities to succeed, too. Tell people you want to make it. Tell yourself you want to make it. Soon all of you will start believing it and already do.

Don

## Counseling Feedback: II

### Chris:

Wow! You get turned on to just about everything, don't you. With the exception of sewing. Even this you don't dislike, though.

You are a very refreshing, warm and sociable young man. I really enjoyed working with you. I like people who have so much energy they don't really know what to do with all of it. Your good nature will carry you a long way.

Although it is difficult to tell by your responses which task you liked the best (your interest was high in everything), they do indicate that you are interested in active things, in doing things. You may not be happy with a desk job, anything in which you spend a lot of time in one position. Even here we can't be certain though, for you had a very high interest in both drafting and clerical tasks, jobs in which you would be content in a job in which you were inactive for long periods of time. This need to be active probably gets you in a little trouble at school, doesn't it?

Anyone with as much energy as you have, Chris, will have a little problem. I guess, a pretty serious one, if you don't know how to learn to control and concentrate it. You may never become very good at anything until you do learn to control it. If you do, there may be little that you can't do. But, what do I mean by control, huh? What we're driving at is your learning how to control yourself. Imagine yourself, for a moment as a young horse. Have you ever seen a colt on a spring day bucking, kicking up its heels, rolling around on the ground, running back and forth across

the pasture until it is just exhausted. Now apart from enjoying itself what has the colt accomplished, other than getting tired. Very little. Compare this colt to a stallion responsible for the survival of a wild herd of horses. He is constantly on the alert for approaching danger. He is capable of leading the herd to good grazing land. He can ward off competing stallions with very skillful combat strategy. He can keep the herd in a tight group where they have the protection of numbers. That stallion can control himself. Oh! He may kick up his heels once in a while, run just for the joy of running, but when he has to he can do just what he wants to do. He has a purpose and he can control his movements well enough to attain that purpose.

People go through this same thing in learning how to do something. They learn how to control themselves. That stallion learned how to defend himself by developing combat skills. You have to do this too, Chris. You probably know how to ride a bike. Before you tried didn't you watch how a skillful rider did it? When you began, you had a goal which you could imagine--skillfully riding a bike. You had seen others do it but you didn't quite know how they did it. Right off the bat, you probably fell down. Slowly, after a few bumps you learned how to balance yourself. You learned how to use the pedals, how to brake, how far to lean when you turned a corner, how to stay upright when you stopped. You learned a very complex skill by learning how to control yourself. Every skill you pick up, Chris, is dependent on your learning how to control yourself. This goes for math, English, welding, drawing, writing, walking, running, sawing, threading, everything. There is always a goal you are reaching for first, then, step by step you learn how to reach that goal. We will talk about this, Chris, the next time we get together. Hang in there!

# SINGER/GRAFLEX SYSTEM - ITS USE IN CORRECTIONAL PROGRAMS IN WISCONSIN

Ricardo G. Cerna  
Vocational Evaluator  
Wisconsin State Prison

Paper Presented at the Iowa Invitational Workshop  
On Assessment Systems and Career Development Programs

Council Bluffs, Iowa  
March 26-27, 1973

## HISTORICAL DEVELOPMENT

The Wisconsin Division of Vocational Rehabilitation has been serving inmates and parolees of Wisconsin's correctional institutions for a number of years. However, prior to 1964, this involvement was limited and primarily concerned with problems associated with physical disabilities such as purchasing artificial limbs, hearing aids and other medical-surgical services which could not be provided through the Division of Corrections' programs.

In 1964, the first pilot program between the Wisconsin Division of Vocational Rehabilitation and Wisconsin's Division of Corrections was begun.

In 1966, the first full-time D.V.R. counselor was assigned to a correctional institution.

In 1967, other counselors were assigned to other correctional institutions and a full-time central office supervisory position was developed to deal with the development and implementation of correctional rehabilitation programs.

1968 was an experimental year. A number of cooperative programs in several areas of vocational training were developed. It was also in 1968 that the concept of establishing a pre-vocational evaluation center at a juvenile receiving center was discussed. It was felt that by establishing

vocational evaluation and counseling services at the reception center, a more complete D.V.R. file could be established, providing for better services.

In August of 1970, the first full-time vocational evaluator was employed by D.V.R. The task was to develop and implement an evaluation unit at Lincoln Boys School, a reception center serving the northern 42 counties of the state of Wisconsin.

During 1971, D.V.R. became involved in the development of the Assessment and Evaluation Centers being formed by the Division of Corrections. The Assessment and Evaluation Centers were placed into operation at both Wisconsin State Prisons, Wisconsin State Prison (W.S.P.) and Wisconsin State Reformatory (W.S.R.) in October, 1972. It was at this time that a vocational evaluation lab at W.S.R. was staffed and equipped by D.V.R. and began functioning as part of the program. The lab at W.S.R. started functioning as part of the A & E program in January, 1973.

#### PROGRAM AT LINCOLN BOYS SCHOOL

The task of developing an evaluation lab at Lincoln Boys School proved to be a very interesting and challenging operation. This was because there were several concepts as to what an evaluation unit was, what it was supposed to do and how it was to operate.

The first step at Lincoln Boys School was to construct work samples and develop a program of vocational evaluation that would meet the needs of clients - males: ages 15-18 years mostly from rural areas of Wisconsin. It was not until approximately a year later that D.V.R. was able to purchase a Singer/Graflex System for use at the school.

Prior to acquiring the S/C System, a study was done to determine if the vocational evaluation results obtained during the boy's second week of stay at the school were valid. A group of 35 boys was re-tested six

(b) weeks after the initial evaluation. The results indicated that although there was an improvement in time performance, this improvement was very consistent. It increased in a predictable curve, so it was decided to keep the evaluation at the beginning of the boy's incarceration. The program called for evaluating all boys, ages 15 through 18 years, coming into the institution. The results of the evaluation were then used to help set up an individual program for each boy.

Because of the two types of work samples available - the ones constructed during the first year and the S/G System - there was an opportunity to evaluate student performance on each type. Keeping in mind that work samples are only one of the tools used during evaluation, the following observations were made:

The S/G System had a much greater face validity. The students responded more positively to the S/G samples than to other work samples with possible exception of the small engine work sample.

The S/G System also provided excellent pre-vocational information on the different job areas, information that was not built in the constructed work samples.

As a result of the face validity and the information provided by the S/G System, the students were able to associate far better the work sample performance with the actual jobs. The evaluation became more meaningful to them. Once an interest area was noticed, other instruments and more specific samples were used to provide additional information.

During the time that most 15 through 18 year olds were evaluated, several facts came into light:

One was that the majority of the students were returning to a school to complete their education. In this case, a vocational evaluation is somewhat premature as vocational interests changed as the student advanced in school and was exposed to other areas of work.



... that most students seen in the lab had, at best, a very limited work experience. For this, the S.G. did an excellent job of providing exposure to different job areas, but the number of areas was limited.

... three, and possibly the most striking fact was that the great majority of students had the capabilities of performing most entry level job tasks that are representative of the work samples. With proper training, the majority of these students could handle a skill job. The key to all this was interest and motivation.

Four, because the great majority of the students had these capabilities, the evaluation results, as far as vocational goals were concerned, were being changed. That is, it was somewhat premature to make long range vocational goals. Since the results of the evaluation were being used for programming students, there were many program changes resulting from changing interests.

However, there was a group that benefited greatly from an evaluation. These were the slow or reluctant learner, the borderline retarded, the socially or culturally deprived, as well as those highly unmotivated toward any type of school training. These students were in the minority of the Lincoln Boys School population.

Incidentally, the school became co-educational on June 1st, 1972. Several of the girls were placed through the program and no significant differences or problems were observed.

As a result of evaluating the program, evaluation of all 15 through 17 year olds being in it was slowed down. Emphasis was placed on those that were going out on an independent placement, or were not to continue in school programs. The evaluation program is still available at any time to anyone who might need for it.

## PROGRAMS AT W.S.P. & W.S.R.

During 1971, the Wisconsin Division of Vocational Rehabilitation became involved in the development of the Assessment and Evaluation (A & E) Centers being developed by the Division of Corrections. The objective of the Centers was to provide a program of assessment and evaluation for each offender admitted (both new and re-admission) to the Prison and Reformatory.

The A & E programs began operation at both the W.S.P. & W.S.R. centers on October 6, 1972. The programs are designed to provide a more meaningful and coordinated approach to the treatment of each offender admitted to the Prison and the Reformatory by informing, motivating, and evaluating him at the beginning of his incarceration. Each offender is involved in the development of his own case plan which utilizes both short and long range goals.

D.V.R.'s primary objective is to determine the number of clients who need vocational rehabilitation services related to the A & E process and to identify the other kinds of services that should be provided.

D.V.R. has equipped and staffed the A & E vocational evaluation labs at W.S.P and W.S.R., as well as provide a counselor and counselor's aide to work in cooperation with the Division of Corrections staff at both A & E centers.

The S/G System was chosen to equip the labs because of the positive experiences with it at Lincoln Boys School. The idea was to use it as a core set of samples and that more specific work samples would be developed as needed.

At the present time, approximately half of the men being admitted are scheduled for vocational evaluation. These men are selected to go through the evaluation lab by the D.V.R. counselor if he feels that there is not enough vocational information to make a tentative rehabilitation plan. However, other members of the A & E staff can also recommend men

for evaluations. Other inmates already in the prison population can also be referred for evaluation by their social worker or re-classification committee.

The present schedule calls for medical and dental examinations as well as orientation the first week. Interviews by D.V.R. and the security coordinator and academic, vocational evaluation begins the third week, if the man is scheduled for it, and finally staffing is started on Thursday of the fourth week.

Results from the California Achievement Test (CAT) and the General Aptitude Test Battery (GATB) are available on all men coming through the vocational evaluation lab. In many cases, these results are low, though not all men with low results can be classified as retarded (mentally). Many of these men have not had a good work record and certainly most have no salable skills.

The men are scheduled for a four day evaluation. So far, only one inmate has refused to go through the evaluation. The overall response from these men has been very positive and the program is seen by most as an honest program, working in their behalf.

The S/G System is used both to present job information as well as to evaluate interest and ability. Other evaluation tools such as the interview, aptitude tests, and interest inventories are used as needed. However, the mere fact that a man goes through the S/G System and the appropriate ratings are given, does not mean that he comes out with a vocational label and a ready-made answer to his vocational problems. Like with any type of evaluation, observation is the key word.

A brief report is written after an inmate has completed the evaluation. It is used together with other reports by the security coordinator, program coordinator, guidance counselor, D.V.R. counselor and a summary of test results at the staffing to help determine an appropriate plan.

The evaluation report includes a summary of job sample results, observation of critical behavior and recommendations. The lab report seems to provide the additional information needed to help determine individual programs.

Usually six men are scheduled each week, although as many as eight and as low as three have been scheduled. Six seems to be the number of men that can be handled by one evaluator in the S/G System without many problems. The main problem in scheduling seven or more individuals is that after the first two stations are completed, scheduling becomes somewhat of a problem. This is because of different work speeds; and the problem is that usually a man has to spend some time waiting for a station to open up. Also, because of numbers, time spent in direct observation is reduced.

The fact that only six men are scheduled per week has posed no problem at W.S.P. because intake has averaged about 12 or 14. Approximately only half of the intake population shows a need for vocational evaluation. At W.S.P., the S/G System seems well accepted by the inmates. Reports from W.S.R. also indicate that response has been positive. The positive response to the S/G System could well be due to the fact that it does not present them with another opportunity for failure. Many of these men, could be said, to suffer from what has been called the "failure syndrom". Where they cannot

perform academically, they can at least perform with their hands. The S/G System does not present a threat to them. It also has face validity, and the men feel that it is a program that is beneficial to them.

So far, no major mechanical problems have occurred. The men have left the operation of the system to the staff - that is, the changing of tapes, film strips, adjustments, etc. Operational cost of consumable supplies per man has been reduced to approximately \$2. The biggest alterations have been: (1) the painting of tool outlines; (2) securing the hooks to the pegboard with wire; (3) use of a card and time clock for recording time and; (4) modification of the blue response sheet to show the errors the evaluator checks for.

Time norms have not been established for the population at W.S.P. These time norms are very different than the ones provided with the S/G System. However, the S/G System is being used only as a tool for evaluation and as a tool, it is only as good as what you make it.

Ricardo G. Cerna



THE USE OF SINGER GRAFLEX WITH THE MENTALLY RETARDED

Richard Schoonover  
Director of the Pottawattamie Career Evaluation Project

Paper Presented at the Iowa Invitational Workshop  
On Assessment Systems and Career Development Programs

Council Bluffs, Iowa  
March 26-27, 1973

I would like to visit with you today about our application of the Singer/Graflex Evaluation System. The system is being utilized as part of a Special Needs (P.L. 90-576) project serving the mentally retarded in Harrison, Shelby, Cass, Pottawattamie, Mills, Fremont and Page counties. These seven counties make up the Area XIII educational structure in southwest Iowa. We are serving 24 school districts within these counties and we will have served about 180 students throughout the area by the end of June.

We are using the Singer/Graflex System in conjunction with our staff to satisfy these program objectives:

- Modification of Curriculum
- Increased Student Awareness of Career Options
- Increased Teacher Awareness of Student Potential
- Increased Information for Vocational Rehabilitation Services

Each of the agencies involved keep us informed of the use they make of the evaluations. With this information, we then can modify our program as needed.

The Singer/Graflex System is housed in an 8 foot x 35 foot mobile unit. This unit is transported between school districts for completing evaluations.

The whole procedure actually began when the individual school districts elected to participate in the project. At that time, an evaluation schedule was developed that indicated the dates for each school's evaluation. The amount of time spent in each school was dependent upon how many educable mentally handicapped students that school enrolled in comparison to the total Area XIII educable mentally handicapped enrollment population. Because of the number of schools participating, and the difficulty in scheduling, it was necessary to combine some school districts.

Prior to the evaluation, we asked the school staff to tell us what they would like to know about each student. In addition to this, we asked for the student's age, his IQ score, his reading level and his math level. We also asked for the student's past history in school and medical problems, if any. By studying this information, we have a better idea of which stations to use in evaluating the student. During the evaluation, our unit evaluator observes the student's performance and work skills. We are just as interested in how the student performs the task as we are in what the final product looks like. We observe the time very closely in the office unit and in the bench assembly station and make a note of this time on the final report.

A final report is prepared on the student's performance in each station. After the student completes the evaluation schedule, which usually consists of 6 to 8 stations, the evaluator will write up the final draft of the evaluation report. This report is then typed onto a form which briefly describes what each station evaluates and below this description is how the student performed in that station. The unit evaluator also writes a summary wherein he gives his overall impressions of the student's occupational maturity. Our evaluator takes into account interest, attitude, performance and quality of the final product in preparing this report.

After the evaluator completes the evaluation report, he gives it to me and I prepare a curriculum modification report to accompany this report. Most of the curriculum recommendations are based upon information supplied to me by the teachers. Prior to evaluation, we ask each teacher to prepare a daily schedule and a curriculum report on each child. By studying these reports, I can determine the academic areas of the student. With this information and what I can glean from the Singer/Graflex evaluation in regards to measurement skill, alphabetizing and work habits, I can, then, prepare a series of recommendations.

I am encouraging the adoption of a career oriented curriculum where each area taught is built around the "world of work." The schools are being encouraged to use their communities as a resource in developing work experience and work study programs. The vocational rehabilitation counselors are contributing a lot to this particular area. I also assist the teachers with adapting the recommendations to their teaching situation. In addition, I also make recommendations on teaching approaches to be used with a particular child and encourage the selected placement of the special education child into regular classes; and, if placement is not possible, I encourage them to develop an independent study unit for the student.

After the two reports are completed, they are distributed to the school system, the vocational rehabilitation counselor and the county superintendent's office. We also hold a staffing with each school to review the evaluations and to come to some type of conclusion about each child. I will return to that school district about once every six weeks to assist with the implementation of recommendations and in any other area that might arise. I also visit with administration and guidance counselors concerning what additional programs they might offer to the special education student.



During the first year of the project, we have concentrated on the educable mentally handicapped student. Most of these students are enrolled in special education classes, although some are integrated into the regular classroom. I encourage some integration for all the students, particularly in the area of vocational classes.

We are not attempting to identify future welders or air conditioner repairmen. We are only trying to determine the student's level of vocational maturity and development. By evaluating the student, we can give the school an idea of where he is vocationally and what skills must still be developed. We feel this has been a profitable experience for the 37 girls and 101 boys who have completed the evaluation, as well as for each school district involved in the project.

Richard Schoonover



Richard Keir



JEVS

H. Kulman, F. Drachman, and F. Stabene  
Vocational Research Institute  
1913 Walnut Street  
Philadelphia, PA. 19103

Presented at the Iowa Invitational Workshop  
on Assessment Systems and Career Development Programs

Council Bluffs, Iowa  
March 26-27, 1973

The Philadelphia JEVS Work Sample Battery consists of 28 tasks or samples. These samples are actual work activities performed in a simulated work setting. They are administered to clients from the easiest to the most difficult, and are thus arranged in a hierarchy of complexity. Sampling is completed when the client has performed all 28 of the tasks, or when he is no longer able to perform satisfactorily.

This system of vocational evaluation is particularly effective when dealing with clients who have low reading levels or problems coping with paper and pencil tests. To minimize work pressures, the required reading level of each sample is kept at about the 4th grade level. Clients are not pressured to work on samples which they do not want to perform.

Work-samples expose clients to a variety of vocational possibilities. As a result of sampling, interest and work-related behaviors are observed, and a job-related performance evaluation is achieved.

All the work samples are related to Volume II of the Dictionary of Occupational Titles. Each work sample has a functional relationship to the Date, People, Things hierarchy of the Dictionary of Occupational Titles, and is therefore, classified in a specific Worker Trait Group Arrangement.

In an orientation prior to work sampling, the client is made aware that he should work as quickly as possible, and that he should perform each sample as accurately as he can. The client can take as long as he needs to perform the individual samples. There is no prior time limit set for his completing it. However, his time for completion and the quality of his performance is compared with pre-established norms based upon the performance of his peers.

Currently, work samples have proven useful in a variety of settings. These include:

1. Public Schools
2. Private Schools
3. Vocational Rehabilitation Centers
4. State Employment Service
5. Correctional Institutions
6. Work Adjustment Programs
7. State Hospitals
8. Veterans Hospitals
9. University Training Centers
10. Private Vocational Evaluation Programs

Ongoing research and innovations are part of the Philadelphia JEVS Work Sample Program. Recently, a research project was completed which supported the efficacy of using work samples as an assessment technique with hard-to-place clients. Current research is directed toward developing new Work Samples in areas of work not covered by the present battery. Seven samples are under consideration, and four are completed. Although prospective units are encouraged to develop their own time and quality norms through guidelines and statistical procedures outlined by the Philadelphia JEVS, a current set of scales developed within the last six months is available for use.

These new scales are easier to interpret and more meaningful to those using the system. An entire revamping of the reporting system (forms for observing, recording, and analyzing the data) has been undertaken in recent months. This new system is now being utilized in all field units. A new Handbook for Evaluators and Supervisors has just been released and is also being utilized by all field units. This Handbook includes changes in administration and scoring of the samples, as well as the changes in norms. Included are pictorial representatives of common errors and correct assembly of samples. Frequent scoring questions and procedures for handling problem situations are also covered.

This Work Sample System is available only through the Philadelphia JEVS. For information contact:

Harold V. Kulman, Director  
 Vocational Research Institute  
 of the  
 Jewish Employment and Vocational Service  
 1913 Walnut Street  
 Philadelphia, Pennsylvania 19103

Currently, cost figures for the Philadelphia JEVS Work Sample

Battery include:

- Work Sample Hardware and Forms required to evaluate 15 clients simultaneously.	\$ 4,000
- Shipping and Handling Charges.	250
- Two week training in Philadelphia at \$600 per person (minimum one (1) person).	600
- Four (4) Technical Assistance visits throughout contract year. . . . 4 days per visit. Room charges, food expenses, and consulting fee . . . . .	<u>2,240</u>
TOTAL . . . . .	\$ 7,090

Units that have their own time equipment may deduct \$196.00 (for a time clock) and \$196.00 (for a time stamp) from the hardware costs.

Depending upon the acquisition of our anticipated SRS grant by the Philadelphia J.E.V.S., units having government affiliation with the Department of Health, Education and Welfare, may deduct the charges for Technical Assistance.

Harold Kulman



Franklin Drachman



Fred Stibenz



The JEVS System in a Community College

Dennis Krehbiel  
Director of Career Evaluation Center  
Des Moines Area Community College  
2006 Ankeny Boulevard  
Ankeny, Iowa 50021

Presented at the Iowa Invitational Workshop  
on Assessment Systems and Career Development Programs

Council Bluffs, Iowa  
March 26-27, 1973

The Des Moines Area Community College has used the JEVS System as a part of its Career Exploration Center for about three years. In order for you to have a better understanding of how we use the system and why we made some adaptations, I want to give you some background on the total Career Exploration Center Program.

The Career Exploration Center (CEC) is a work evaluation and exploration program. Our objective is to assist people in identifying their abilities, skills, and interests and then to guide them toward meaningful employment. We not only want to help them learn what kind of work they would like to do but what they can do best.

How does CEC accomplish this? Through the four components that make up the evaluation-exploration program. They are: work exploration, educational evaluation, JEVS and counseling.

The work exploration component is a hands-on experience in numerous jobs. We have four occupational groups where exploration is possible; Business, Graphics, Industrial-Mechanical and Service Occupations. In each of these exploration areas is equipment and materials for our students to get their hands on and to use. They are given job tasks or work samples that simulates a real work task. Through this process the student can learn the pros and cons of a wide variety of occupations.

The educational evaluation component is used to determine the academic weakness, if any, that a student may have. It is important to determine any obstacles that may prevent the student from being successful. Suggestions are made to the student on how he can correct his educational weaknesses.

Counseling is an important part of the overall program. In the two or three weeks a student is in our program, he will be seen several times by either our counselor or the psychologist. During the interviews the counselors try to help resolve any personal problems that may prevent successful employment and to interpret evaluation information. In the final interview, the counselor makes recommendations and helps the student lay plans for the future.

The Center has a staff of 12. There are four work evaluators, one educational evaluator, a counselor, a psychologist, an occupational consultant, a secretary, a supervisor and two JEVS evaluators. The work evaluators are people experienced in the trades that they are evaluating in and may or may not have any college training. The supervisor, counselor and psychologist are the only positions requiring a degree. One JEVS evaluator has a B.S. in Industrial Psychology and the other is a few hours short of a degree. However, it is not at all necessary for the JEVS evaluator to be a degreed person. Qualifications such as intelligence, alertness, sensitivity to people, the ability to develop rapport and the sincere desire to work with and assist people are much more important than a degree.

The population served by our Center comes from a wide variety of sources. We receive students from Voc. Rehab., MDA, State Employment Office, community correction programs and public schools-any institution or agency working with the disadvantaged and handicapped.

Who are the disadvantaged and the handicapped? It seems there is always some

confusion about who they are. They are viewed from a different frame of reference as different people. So that we are all thinking about the same people, let me give you some of the causes of disadvantage and handicapped that are listed in guidelines put out by our Special Needs Section of the Iowa Department of Public Instruction.

Causes of Disadvantaged	Causes of Handicapped
Poor educational background	Mentally retarded
Home does not provide motivational or educational stimulation	Learning disabled
Lives in poverty	Seriously emotionally disturbed
Family is dependent on public assistance	Crippled
Member of a migrant family	Visually handicapped
Undesirable home and/or community environment	Hearing Impaired
	Other health impairments

The Career Exploration Center is located in the Industrial Manufacturing Building on the Ankeny Campus. Besides the CEC, this building also houses tool and die, welding and air conditioning training programs. The setting is definitely an industrial one and not too much different than what is recommended for a JEVS operation. The room JEVS is located in what was designed to be a drafting room and has a tile floor and a suspended ceiling with fluorescent lighting.

Our students do not spend all day in the JEVS component as they may in another JEVS operations. Our students are scheduled into three different areas each day. They spend two or two and one-half hours in each area. Example: a student may spend two hours in graphic arts work exploration, two hours in business occupation exploration and two and one-half hours in JEVS during one day. Each day the schedule changes. Usually it takes between 12 and 24 hours to complete



JEVS depending on the ability level of the student.

We use JEVS primarily to gain personality information, dexterity and coordination information and to determine the occupational grouping where success is likely. Since our program tries to stay away from standardized testing as much as possible, our psychologist likes and depends on the personality information gained from JEVS. In some ways it is more valuable and usable than personality information gained from paper and pencil tests.

We have modified JEVS in basically only two ways. We do not give all of the work samples and normally only use 20 of them. The other variations from JEVS procedures is that we have only two evaluators and no JEVS supervisor. Our evaluators do the work of both the evaluator and supervisor. They give the feedback interview and write the report for our counselors. Each evaluator has from 5 to 7 students to observe at a time. Otherwise, we follow JEVS guidelines and procedures.

The JEVS program was shortened for two reasons. One was because we needed to shorten the overall amount of time in our program. The other was because some of the JEVS tasks were duplicated in our work exploration areas. We first took a close look at the necessity of all of the work samples because of our need to shorten it. Below is a list of the work samples dropped and the rationale behind why that particular sample was selected.

Work Sample	Reason
Rubber stamping	Simple, monotonous and drew complaints from the students
Budget Assembly	Time consuming and difficult for the evaluator to score. Info gained from this one can be gotten from others.

File Sorting	Very simple task, students thought ridiculous
Metal Square Fabrication	Duplicated in Industrial-Mechanical work exploration area
Hardware Assembly	Very similar to nuts & bolts, bothersome to disassemble
Typing	More fitting to our business exploration area (since dropped by JEVS also)
Blouse & Vest Making	Expensive, time consuming and employment not available in our locality

We have not destroyed the work samples dropped and still have them. They are used on occasion when they are more appropriate for an individual. Most of the ones we dropped are simple tasks. They sometimes are used for the person with limited abilities.

JEVS has some definite strengths. The primary one is that it is an objective evaluation tool. We in the work evaluation business need to do more to make our work sampling process more objective. It is all too easy to use terms such as "I feel", "it seems", "it would appear", and other indefinite terms in referring to a person's capability in performing a particular task or job. JEVS was particularly useful to us as a new evaluation program. It is standardized and has norms. It gives definite data about what tasks a student can or cannot do.

Another strong point is that JEVS will indicate a grouping of occupation where the student would be able to succeed. This information is made more useful through correlating it to the Dictionary of Occupational Titles.

Another plus for JEVS, as I have already mentioned, is its useful personality information.

Like any system, JEVS has its weaknesses. We have found that it is difficult for the students to relate the individual work samples to any real work situation.

It is important to give a good orientation and explanation of why and how it works.

Another drawback is the time involved in disassembly of the work samples. The work samples, of course, must be taken apart before they can be used again. Our evaluators do this themselves. Not only do they not like to do it, but it distracts them from their observation duties.

Our evaluators are very critical of having to lower a person's rating because of giving additional help. They have stated it is difficult to follow this guideline to the letter. I was happy to hear Dr. Kulman say some changes have been made in this procedure.

The Career Exploration Center has encountered no real difficulties in using the JEVS system. We feel it is a very valuable and useful component of our total program.

Dennis Krehbiel



## The Tower System

Bernard Rosenberg, Director  
Vocational & Industrial Rehabilitation  
Institute for the Crippled and Disabled  
340 East 24th Street  
New York, New York 10010

### HOW DOES TOWER WORK?

The TOWER System of vocational evaluation uses the work sample approach to determine the job potential of handicapped persons.

Currently, TOWER employs 94 work sample tasks, patterned after actual jobs in business and industry, which represent 14 broad occupational areas.

Qualitative and quantitative standards are based upon performance of non-handicapped workers. TOWER's usefulness as a predictive technique is implemented by criteria, scoring aids and records.

Pioneered and developed by the Institute for the Crippled and Disabled in 1937, the TOWER vocational evaluation technique is used by rehabilitation agencies and institutions throughout the United States and by organizations serving the handicapped in other countries.

### TOWER TECHNIQUES

Studies of clients who completed the four to five week evaluation program at ICD indicate a significant correlation between TOWER ratings, trade training scores and ultimate job placement.

TOWER's flexible and adaptable approach is used to assess disabled and socially handicapped persons, ranging from critical to routine, on many occupational levels. It is a reliable, accurate method for determining the

vocational capabilities of severely disabled persons and those who, because of cultural or other limitations, cannot be precisely tested with the other techniques.

Conducted in a simulated environment that would be found in industry, TOWER's work sample approach is designed to reveal the totality of personal traits, including interest, work tolerance, work habits and attitudes as they relate to the work experience, as well as specific vocational aptitudes and skills.

The manufacture of useful products in TOWER, such as brooches in jewelry manufacturing and picture frames in leathersgoods, has proven a major factor in stimulating client interest, motivation and involvement, which are essential to the attainment of rehabilitation goals.

By exposing the disabled client to mock-ups of the actual work situation and the myriad of demands implicit in it, the TOWER System enables the client to test his own ability to adjust to the work experience.

Concurrently, it provides a laboratory in which the team of rehabilitation specialists in non-vocational as well as vocational disciplines can confirm previous diagnoses, set realistic client goals and gain new and valid insight into client progress.

#### COMPONENTS OF THE TOWER SYSTEM

The TOWER System is organized into four components:

- (1) The TOWER Textbook
- (2) The Evaluator's Manual
- (3) One-drawer file case containing all printed material required for operating a TOWER evaluation program
- (4) A 30-minute full color and sound film, "The TOWER Evaluators", which is used for orientation of professional persons and clients, and for development of sources of referral to TOWER

## THE TOWER TEXTBOOK

The TOWER textbook delineates the theory, development, purpose and application of the TOWER System against a broad background of contemporary trends in vocational evaluation.

The 1967 edition, issued as part of ICD's Golden Anniversary celebration, has been reorganized, rewritten and amplified to reflect the evolution of the work sample technique during the past decade.

The textbook establishes guidelines for those who have adapted or are contemplating adaptation of the TOWER System to the needs of their own institutions and agencies. It also serves as a text for students in many rehabilitation disciplines and as a valuable source book for professional and administrative personnel. It may be purchased by anyone at \$7.00 per copy.

## THE EVALUATOR'S MANUAL

The Evaluator's Manual is a comprehensive looseleaf book for the evaluator's use. It comprises 425 printed pages, including copies of all TOWER evaluations, response sheets and criteria, together with plastic scoring aids, general orientation data and detailed descriptions of the employment possibilities related to each category of testing.

## FILE CASE OF TOWER SYSTEM EVALUATION MATERIALS

The third component--the one-drawer file cabinet--contains TOWER evaluations and printed response sheets for client use, and report forms for the evaluator's use in analyzing and reporting client performance.

Space is provided for the maintenance of records and examples of past client performance.

The complete set of printed materials is priced at \$325 plus postage and is available only to those completing the TOWER Evaluator's course at ICD. Persons taking this course under the auspices of the Rehabilitation Services Administration receive a set of these materials in conjunction with their training.

FILM--"THE TOWER EVALUATORS"

This full color and sound, 16-millimeter film depicts the vocational evaluator of three major types of disability.

NEW AND REVISED TOWER SYSTEM EVALUATION CATEGORIES

CLERICAL

1. Business Arithmetic
2. Filing
3. Typing
- 3 a. One-hand Typing (Alternate)
4. Payroll Computation
5. Use of Sales Book
6. Record Keeping
7. Correct Use of English

DRAFTING

1. T Square, Triangle
2. Compass
3. Working Drawing
4. Drawing to Scale
5. Geometric Shapes

DRAWING

1. Perspective
2. Forms, Shapes and Objects
3. Shading, Tone and Texture
4. Color
5. Free Hand Sketching

ELECTRONICS ASSEMBLY

1. Color Perception and Sorting
2. Running a 10 Wire Cable
3. Inspecting a 10 Wire Cable
4. Lacing a Cable
5. Soldering Wires

### JEWELRY MANUFACTURING

1. Use of Saw
2. Use of Needle Files
3. Electric Drill Press
4. Piercing and Filing Metals
5. Use of Pliers
6. Use of Torch in Soldering
7. Making Earrings and Brooch Pin

### LEATHERGOODS

1. Use of Ruler
2. Use of Knife
3. Use of Dividers
4. Use of Paste and Brush
5. Use of Scissors and Bone Folder in Pasting
6. Constructing Picture Frame
7. Production Task

### LETTERING

1. Lettering Aptitude
2. Alphabet and Use of T Square
3. Use of Pen and Ink
4. Use of Lettering Brush
5. Brush Lettering

### MACHINE SHOP

1. Reading and Transcribing Measurements
2. Blueprint Reading
3. Measuring With a Rule
4. Drawing to Measurement
5. Metal Layout and Use of Basic Tools
6. Drill Press Operation
7. Fractions and Decimals
8. Measuring With the Micrometer Caliper
9. Mechanical Understanding

### MAIL CLERK

1. Opening Mail
2. Date-Stamping Mail
3. Sorting Mail
4. Delivering Mail
5. Collecting Mail
6. Folding and Inserting
7. Sealing Mail
8. Mail Classification
9. Use of Scale
10. Postage Calculation

### OPTICAL MECHANICS

1. Use of Metric Ruler
2. Use of Calipers
3. Lens Recognition
4. Lens Centering and Marking
5. Use of Lens Protractor
6. Hand Beveling and Edging



### PANTOGRAPH ENGRAVING

1. Introduction to the Engravograph (Pantograph) Machine and Determination of Aptitudes for Setting Pantograph Arm Ratios
2. Setting Up, Centering Copy and Determining Specified Ratios
3. Use of Workholder and Adjustment of Cutter
4. Setting Up and Running Off a Simple Job

### SEWING MACHINE OPERATING

1. Sewing Machine Control
2. Use of Knee Lift and Needle Pivoting
3. Tacking and Sewing Curved Lines
4. Upper Threading
5. Winding and Inserting Bobbin
6. Sewing and Cutting
7. Top Stitching

### WELDING

1. Measuring
2. Making a Working Drawing
3. Identifying Welding Rods
4. Use of Acetylene Torch
5. Use of Rods and Electrodes
6. Use of Torch and Rod
7. Measuring and Cutting Metal
8. Soldering

### WORKSHOP ASSEMBLY

1. Counting
2. Number and Color Collation
3. Folding and Banding
4. Weighing and Sorting
5. Counting and Packing
6. Washer Assembly
7. Inserting, Lacing and Typing
8. Art Paper Banding

### TOWER EVALUATOR'S INSTRUCTION

A three week training course for TOWER evaluators, conducted by experienced ICD vocational evaluation personnel, provides thorough orientation and enables trainees to gain practical as well as theoretical experience in administration and evaluation procedures.

It also teaches trainees how to establish an evaluation unit using the TOWER methodology.

Likewise, it functions as an overview of the operations of a multi-disciplinary, comprehensive rehabilitation center in which TOWER evaluation is an integral part.

To be eligible for TOWER training, a person must have a specific assignment with an established agency or facility to conduct a vocational evaluation program.

Grants and stipends provided by the Rehabilitation Services Administration, United States Department of Health, Education, and Welfare, cover living expenses and specified costs of the course, except for tuition. These benefits are available to citizens of the United States. The three week course tuition fee is \$200 for U.S. Citizens. Fees and charges for citizens of other countries are available on request.

A complete set of TOWER System materials (textbook and evaluator's manual) is furnished to the agency, facility or institution represented by an accepted trainee upon his or her completion of the course. Others may purchase the complete set of TOWER materials after completing the course.

The TOWER System is a copyright development of the Institute for the Crippled and Disabled. For further information or purchase, write to:

The TOWER System  
Institute for the Crippled and Disabled  
340 East 24th Street  
New York, New York 10010

RESEARCH AND TRAINING CENTER  
DEPARTMENT OF REHABILITATION AND MANPOWER SERVICES  
UNIVERSITY OF WISCONSIN - STOUT

COMPARISON OF THE JES, STINGER GRADEN  
AND TOWER WORK EVALUATION SYSTEMS

Benais L. Dunn

November, 1972

There are currently three work sample systems available on the market for a person reviewing each system, with an eye toward its potential opportunity in his situation. It is apparent that each system offers certain advantages, but also possesses disadvantages.

The purpose of this paper is to present a comparison of the three evaluation systems. This comparison is based upon a review of the available and other published materials which are available for each system. Consequently it is to note that some system details which are covered in the literature are not included in this paper. The author is not responsible for any errors or omissions which may appear in this paper. The author is grateful to the staff of the University of Wisconsin - Stout for their assistance in the preparation of this paper.

---

The creation of this paper was supported, in part, by grant number 100-1-1001-1-1001, Rehabilitation Services Administration, Social and Rehabilitation Services, Department of Health, Education, and Welfare. A modified version of this paper appears in Sadler, J. (Ed.), Assessing the Use of the Job Sample Program: A Review and Evaluation. (Stout, WI: Interaction Research Institute, 1972).

1. Dunn, B. L. "Observations on Similarities between JES and TOWER Systems of Work Evaluation." (Stout, WI: Center for Manpower Research, 1972). Published in Journal of Vocational Behavior, 10(1), 1-10.

This comparison of systems can be used as a guide for potential users to determine the potential applicability of each system to their particular situation. A summary of reactions of potential users to each system is included to facilitate this use of the comparison. Each of the systems covered in this paper is subject to modification and revision. A potential user should contact the system developer for up-to-date information prior to making a final decision with regard to purchase.

Client	Description of Service	Number of Clients	Number of Samples
<p>a. 100</p> <p>b. 100</p>	<p>a. 100</p> <p>b. 100</p>	<p>a. 100</p> <p>b. 100</p>	<p>a. 100</p> <p>b. 100</p>
<p>a. 100</p> <p>b. 100</p>	<p>a. 100</p> <p>b. 100</p>	<p>a. 100</p> <p>b. 100</p>	<p>a. 100</p> <p>b. 100</p>
<p>a. 100</p> <p>b. 100</p>	<p>a. 100</p> <p>b. 100</p>	<p>a. 100</p> <p>b. 100</p>	<p>a. 100</p> <p>b. 100</p>
<p>a. 100</p> <p>b. 100</p>	<p>a. 100</p> <p>b. 100</p>	<p>a. 100</p> <p>b. 100</p>	<p>a. 100</p> <p>b. 100</p>
<p>a. 100</p> <p>b. 100</p>	<p>a. 100</p> <p>b. 100</p>	<p>a. 100</p> <p>b. 100</p>	<p>a. 100</p> <p>b. 100</p>
<p>a. 100</p> <p>b. 100</p>	<p>a. 100</p> <p>b. 100</p>	<p>a. 100</p> <p>b. 100</p>	<p>a. 100</p> <p>b. 100</p>
<p>a. 100</p> <p>b. 100</p>	<p>a. 100</p> <p>b. 100</p>	<p>a. 100</p> <p>b. 100</p>	<p>a. 100</p> <p>b. 100</p>
<p>a. 100</p> <p>b. 100</p>	<p>a. 100</p> <p>b. 100</p>	<p>a. 100</p> <p>b. 100</p>	<p>a. 100</p> <p>b. 100</p>

	II B	SINGER/GRAFLEX	FOWLER
1. Direct contact with client	a. Direct contact with client is "initial", feedback on performance & behavior occurs at end of process b. Stress realistic work atmosphere & setting c. 7 to 10 hrs (in. to 30 hrs.)	c. extensive involvement through ratings of interest & performance by clients d. stress realistic work atmosphere & setting e. approximately 22-25 hrs.	c. not specified; little provision for client feedback d. stress realistic work atmosphere & setting e. approximately 3 weeks
2. Direct contact with client	a. procedures clearly indicated, materials needed, etc. b. primarily verbal and demonstrations written instructions used only when they are a requirement in a job area	a. procedures clearly indicated including layout, materials, & supplies needed b. all instructions are given using verbal (tape) instructions, illustrated with a slide. Programmed A-V material is occasionally supplemented with written material c. not specified d. evaluator encouraged to provide assistance necessary for client to complete the task	a. procedures clearly indicated; purpose and materials stated b. primarily written instructions supplemented by evaluator explanation and demonstration when needed c. encouraged for up-grading d. evaluator encouraged to ensure client knows how to do task before he begins work
3. Scoring	a. use of time clock by client required for each sample	a. evaluator times client	a. timing necessary but no procedures established for who does timing

Time Interval	How	Time Interval	How
a. work performance	<p>1. checked on 22 work samples for the month</p> <p>2. rated on a 5-point scale; norms developed from 2000 disinterested</p>	<p>1. checked on 22 work samples for the month</p> <p>2. rated on a 5-point scale; norms developed from "Standard Requirements" in Rochester, N.Y.</p>	<p>1. time intervals vary; amount of work necessary to complete work on the scale is rated on a 5-point scale; norms developed at ICB, but group not specific</p>
b. work behavior	<p>1. most samples use random check of 10 items compared to scoring criteria; others require a complete check</p> <p>2. minimal use made of scoring aids</p>	<p>1. check all items against scoring criteria provided</p>	<p>1. check all items against scoring criteria provided</p>
c. quality norms	<p>1. rated on a 5-point scale; based on U.S. Dept. Military contract specifications</p> <p>2. time and quality given equal weight; emphasis varies in individual cases</p>	<p>1. some use made of scoring aids</p> <p>2. rated on a 5-point scale; norms developed in Rochester (see (c) above)</p> <p>3. emphasis is on quality of finished product</p>	<p>1. extensive use of transparent overlays</p> <p>2. rated on a 5-point scale; norms developed at ICB</p> <p>3. emphasis is on quality of finished product</p>
6. observation	<p>1. work performance specified in performance of samples; each sample has factors listed</p> <p>2. work behaviors to be observed are defined and defined</p>	<p>1. few work performance factors specified; none for individual samples</p> <p>2. work behaviors to be observed are defined</p>	<p>1. few work performance factors specified; none for individual samples</p> <p>2. work behaviors are specifically defined</p>

<p>Final report</p>	<p>c. uses 3-point rating system for most performances and behaviors; points on scale clearly defined and illustrated</p> <p>d. extensive observations; recordings for individual samples on specific factors; all performance &amp; behavior observations summarized on a daily basis</p>	<p>c. uses 5-point rating system; points on scale not clearly defined for individual performances and behaviors</p> <p>d. frequent observations are not emphasized</p>	<p>c. uses 5-point rating system; points on scale not clearly defined for individual performances and behaviors</p> <p>d. frequent observations are not emphasized</p>
<p>7. Reporting</p> <p>a. forms</p>	<p>a. standard forms included for work sample recording; daily observation summary; feedback interview; final report</p> <p>b. standard format, includes ranking of performance on samples; extensive written comments on performance &amp; behavior</p>	<p>a. standard forms included for interest &amp; performance rating; also includes picture interest test</p> <p>b. narrative recommended</p>	<p>a. standard forms included for attendance &amp; punctuality; vocational evaluation report; performance summary</p> <p>b. primarily global ratings; personal contact with counselor recommended</p>
<p>b. final report format</p>			



<p><u>S. Util.</u></p> <p>a. occupational counselor</p>	<p>a. exposed to a variety of vocational areas; provide client with information for vocational planning</p>	<p>a. exposed to a variety of vocational areas; feedback interviews</p>	<p>a. extensive amount of occupational information provided to client</p>
<p>b. occupational recommendations</p>	<p>b. highly related to DOT; wide breadth of jobs; geared for both training and job placement</p>	<p>b. highly related to DOT; primarily oriented to training</p>	<p>b. limited range of related jobs, act highly related to DOT; primarily oriented to training</p>
<p>c. counselor utilization</p>	<p>c. oriented toward counselor</p>	<p>c. not specified</p>	<p>c. counselor involvement in process recommended</p>
<p>d. research evidence</p>	<p>d. positive</p>	<p>d. in process</p>	<p>d. research evidence is equivocal</p>
<p><u>u. Training in System</u></p> <p>a. training required</p>	<p>a. yes</p>	<p>a. no</p>	<p>a. yes</p>
<p>b. training available</p>	<p>b. yes</p>	<p>b. yes</p>	<p>b. yes</p>
<p>c. duration</p>	<p>c. 2 weeks</p>	<p>c. 2 days</p>	<p>c. 6 weeks</p>
<p>d. follow-up</p>	<p>d. four technical assistance visits to assist with establishment of facility &amp; maintenance of standardized procedures; during 1st year. Additional visits during 2nd year</p>	<p>d. 30 days follow-up by telephone</p>	<p>d. no</p>



SINGER/GRAFLEX TOWER

I. Current Status	JEVS	SINGER/GRAFLEX	TOWER
<p>a. availability</p> <p>b. approximate cost to set up sites</p>	<p>a. available through Philadelphia JEVS</p> <p>b. \$4,250 cost of equipment &amp; shipping, 5000 per person for training at Philadelphia JEVS.</p> <p>\$2,240 for 4 technical assistance visits</p>	<p>a. available through Singer/Gr. flex</p> <p>b. \$8,925 + orientation (\$200) + freight FOB Morton Grove Illinois</p>	<p>a. available through ICD</p> <p>b. \$4,500 for hardware and tools &amp; \$500 for instruction manual and training</p>
<p>c. future development</p>	<p>c. under active research changes to be made based on empirical evidence</p>	<p>c. under active development; system purchasers to be involved in research activities</p>	<p>c. no developmental or revision activities indicated</p>
<p>II. Positive Features</p>	<p>a. progression of sample from simple to complex can handle a wide range of clients</p> <p>b. procedures are well laid out &amp; described; most samples utilize a combination of verbal &amp; demonstrated instructions (level of comprehension required of the client)</p> <p>c. ease (criteria are established for each sample); norms for time &amp; quality</p>	<p>a. permits client to explore and develop interests; orients client to job areas</p> <p>b. use of A-V materials provides a more standardized format; not as time consuming for evaluator; involves client</p>	<p>a. use of team approach and involvement of the client in evaluation process</p>
<p>5. administration</p>			
<p>c. scoring</p>			<p>c. use of overlays &amp; general format leads to ease of scoring and has high objectivity</p>

\*based on reactions of 30 vocational evaluators. Data from Dunn, D.J., perceived usefulness of work sample systems among short-term training participants. Short-term Training Program, Department of Rehabilitation and Manpower Services, University of Wisconsin-Stout, January 1972.



	JFV'S	SINGER/GRAFLEX	POWER
d. observations	<p>1. factors to be observed are defined &amp; listed for each sample; ease of use; standard report format</p> <p>e. battery is linked into DOT; has a wide range of tasks; useful to counselors</p>	<p>d. client has to rate himself</p> <p>e. useful in exploration and development of interests</p>	<p>e. useful in making recommendations for vocational training</p>

## THE WIDE RANGE EMPLOYMENT SAMPLE TEST

Guidance Associates of Delaware, Inc.  
1526 Gilpin Avenue  
Wilmington, Delaware 19806

The Wide Range Employment Sample Test (WREST) was developed at Opportunity Center Inc. (OCI) in Wilmington, Delaware. OCI is a workshop for the mentally and physically handicapped and serves as a training resource to develop basic work production skills. The work activities at OCI were the basis of development for the work samples included in the WREST. The work samples are referred to as the Jastak-King Work Samples. Mrs. Dorothy E. King developed the work samples and Dr. Joseph F. King standardized them. Standardized scores have been developed for both handicapped and nonhandicapped population groups.

The WREST was originally developed to evaluate the (through observation) production of work relative to economy of time and movement.

Production time and error norms were established for the OCI workshop population (300) and for persons actually employed in regular production shops, industry, commerce, and service (100). The industrial norms have been described as being helpful in estimating the readiness of a client to enter regular employment after completing a work adjustment and training program.

Ten work samples comprise the WREST. They represent manual and clerical job situations found in commerce, industry, and service. Each sample is organized to obtain a 7-15 minute sample of a work task.

Materials representing the samples are compactly stored in a portable kit measuring 15 x 15 x 15 inches. Work sample activities include folding, stapling, packaging, measuring, assembling, tag stringing, pasting, collating, color and shade matching, and pattern matching.

The specific work samples and what they entail are described below.

Sample No. 1 - Folding

This activity would relate mostly to secretarial - clerical - general office and statistical procedure. It entails the handling and folding of paper envelopes - glue - tags. Some degree of dexterity and orderliness is required.

Sample No. 2 - Stapling

Requires a degree of spatial judgment - ability to use mechanical devices and manual energy output related to industrial application such as spot welding, heat sealing, carton manufacture, book binding, press operation (drill and printing), stamping, sewing, general small machine operation, requires some degree of accurate control.

Sample No. 3 - Bottles and Pegs

Requires dexterity, color recognition, coordination, application to industry would be in small parts packaging and order filling in automotive, electronics, machine parts, toys, large variety of any type of small items.

Sample No. 4 - Rice Measuring

Entails the filling of vials in varying measurements with fine material - requires good judgment of quantities and some degree of speed of estimation.

Industry application: drug (wholesale) industry, food, paint, cosmetics, etc., where specific measurements are required.

#### Sample No. 5 - Screws

Requires the ability to follow a prescribed pattern or sequence using various kinds of nuts, bolts, and washers. Requires the ability to recognize pattern and pattern construction, good dexterity, mechanical aptitude.

Industry application: wide range of mechanical and semi-mechanical fastening of related parts, readily adaptable to solid state electronic circuitry, placing of diodes, resistors, transistors, etc., on a circuit board and fastening with either screws, solder, etc.

#### Sample No. 6 - Tags

The ability to work with two different types of materials - semi-flexible (tags) and very flexible (lacing) - requires some degree of finger dexterity and judgment (keeping ends even). Applications are quite naturally garment industry, textile-parts identification, any type of application requiring identity and dexterity.

#### Sample No. 7 - Swatch Pasting

Requires neatness, good judgment with space relation, some degree of artistic appreciation, reasonable amount of dexterity. Application to industry would be creation of sales samples, crafts, display, advertising paste-up, artistic arrangement.

#### Sample No. 8 - Collating

Entails the compiling of different colors (color recognition) in a prescribed sequence or order (patterns) and filing in a prescribed manner

(neatness and order). Applicable to office procedures, inventory control, order packing.

Sample No. 9 - Colors

Ability to differentiate colors, hues, shades, placement judgment, arrangement. Again applicable to preparation of sales material for yard goods, paints, advertising, craft work, displays.

Sample No. 10 - Pattern Matching

The ability to differentiate colors, analyze arrangements, structure placement and composition, adaptable to arts, construction of complex models, pattern making, architecture, marine-aircraft construction, electronic circuitry, and the like.

The WREST was developed for use with individuals between the ages of 16 and 35 and can be administered individually or in small groups (3 to 6 persons). It takes approximately 1½ hours for individual administration and 2 hours for group administration. The test may be readministered at regular intervals to derive a learning curve which distinguishes between learning rates of those who are mentally retarded and those who may test retarded initially but are not. The test should be administered and interpreted by trained evaluators, psychologists, and personnel and employment specialists.

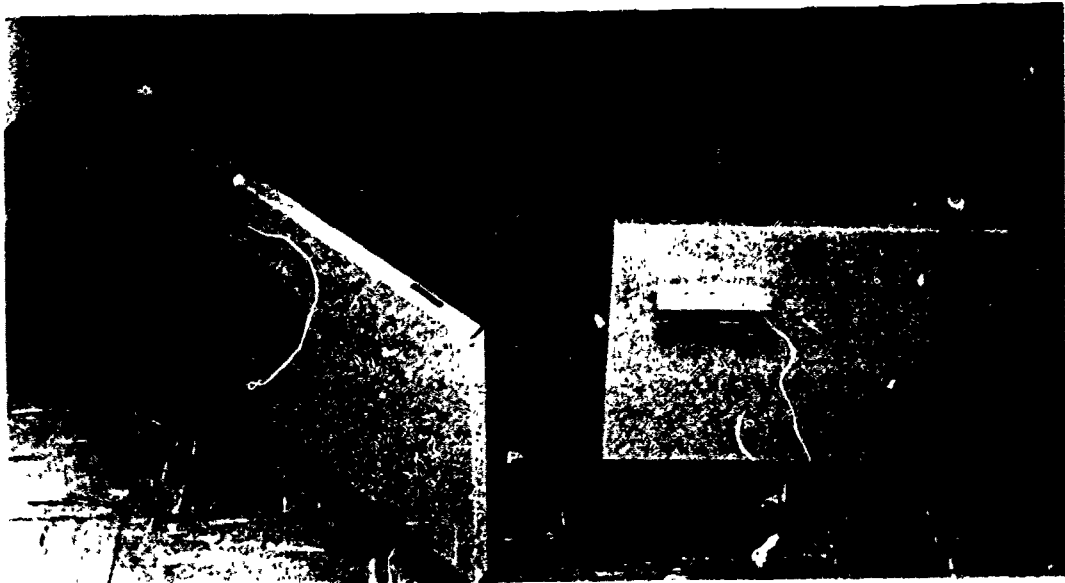
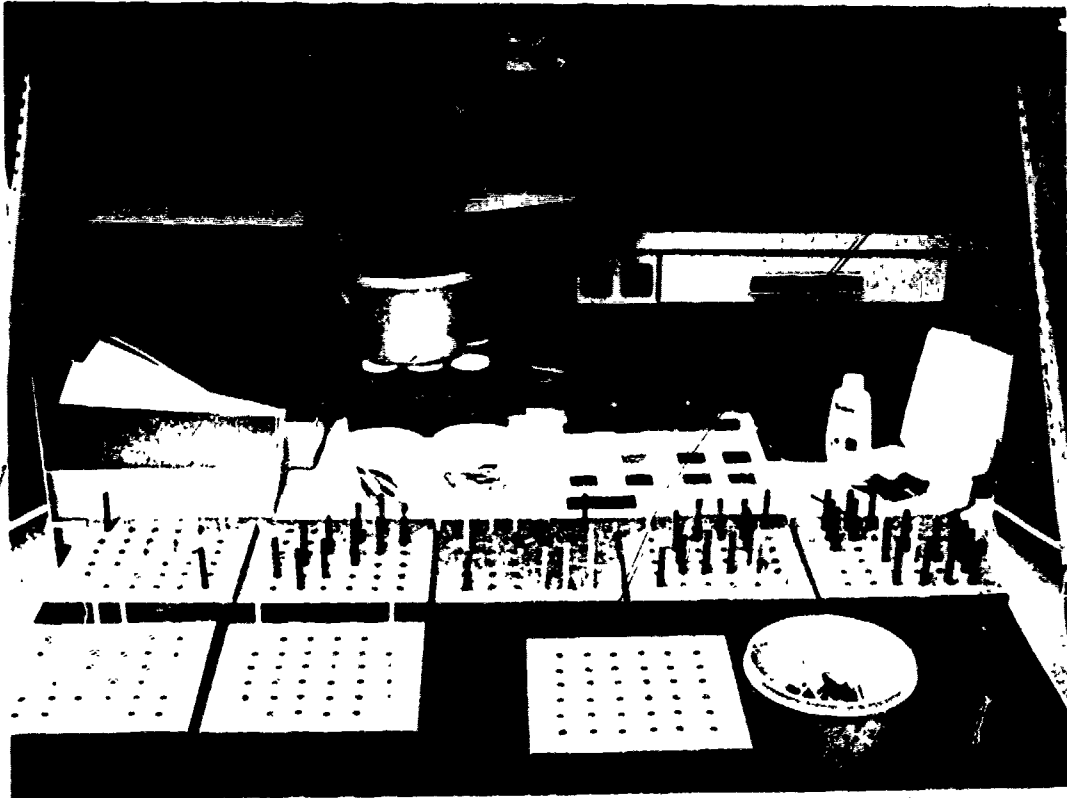



A manual is available on the WREST which includes specific directions for administering the test. Norms and measures of variability for the ten tasks are also included.

Scoring of the WREST can be done by hand. Time and errors are considered in the scoring. The results are expressed in stanine scores for each subtest (10). The ten scores are added to obtain a total performance score for each person.

The authors of the WREST claim that the WREST can be used for the following:

(1) To study the industrial efficiency of a person in terms of time and quality of production.

(2) To check in a standardized manner an individual's approach to a simulated job setting.

(3) To observe attitudes, effort, production rate, and a number of, emotional, motivational and social variables needed for success on the job.

(4) To counsel with a wide variety of individuals--the disadvantaged, the underemployed, the mentally maladjusted, and retarded.

(5) To train disabled persons in the specific skills found lacking for efficient production.

For more information, contact Guidance Associates of Delaware, Inc., 1200 N. Lincoln Ave., Newark, Delaware 19705 - Tel. (302) 652-1900 or (302) 652-1100.

REFERENCES

WREST Manual, Guidance Associates of Delaware, Inc.

WREST Manual, Guidance Associates of Delaware, Inc.

COSTS CONT.

Work Sample Kit and 25 Record Forms - \$395.00

Work Station Cabinet - \$250.00 (optional)

References

Jastak, J. F., and Jastak, S. R. Guidance Associates of Delaware, Inc. Wilmington, Delaware, 1972.

Jastak, J. F. and Jastak, S. R. The Jastak-King Work Samples Manual. Wilmington, Delaware: Guidance Associates of Delaware, Inc. 1972.

## Talent Assessment Tests

Wilton E. and Maurine K. Nighswonger  
Talent Assessment Programs  
7015 Colby Avenue  
Des Moines, Iowa 50311

### Introduction

A testing program designed to be utilized on people of all intelligence levels and all levels of capabilities must, of necessity, be action oriented. Paper testing of those who read slowly and with difficulty does not provide a true measure of the people being tested. To appear completely usable as an instrument designed to reflect the inherent characteristics of an individual, which are applicable to work, a composite test battery should reflect several capabilities. It should be capable of accurate measurement of the attributes a person has at the time of his first appearance. This serves as a reference point from which all change in an individual can be measured. The characteristics must be measured with enough definition and accuracy that the results can be developed into norm tables and be related to industrial standards. The entire operation must be accurate enough to permit realistic projection and program development.

The assessment battery to be described is composed of eleven action tests designed to measure the characteristics applicable to work in industrial or technical lines. These Action Tests are designed to hold the pupil in a positive frame of mind and serve as guidelines for interest and capacity exploration in career education. The tests will probably appear new and different to most pupil personnel services people because

they have not been commonly used in school settings. They are functional level tests of career-related aptitudes. The list of titles would include visualizing structural detail, discrimination of objects by size, shape, color, and touch, dexterity, electrical flow diagrams, and memory for structural detail.

During the course of testing, many subjective observations can be noted and recorded for the benefit of instructors, counselors, and coordinators. Some of the items to be observed are:

Appearance

Mode of relating

Personal organization

Emotional control

Work approach

Communication

Objective recognition

Realistic level

Punctuality

Other items that may be observed are: voiced aspirations or goals related to work, the amount and type of supervision required during the testing effort, how the client was handled, changes noted during the testing, and why some tests were not attempted. The tests will give some indication of the probable level of operation by demonstrating physical limitations and threshold tolerance.

Initial assessment should require only about two hours. It will serve as a reference base from which change and development can be measured during periods of exploration and work try-out. Combined with psychological, academic, and medical test results, it gives a very real picture of an individual.

It is seldom necessary to give all the tests to each person. Practiced raters learn to quickly select tests that appear most appropriate for a pupil, in the light of his age, education, experience, physical limitations, mental limitations, and apparent realistic desires.

The "A" profile sheet illustrates a working form that can be utilized for recording pertinent information related to the person being tested and the results from various assessments being applied. Using norm scales to graph the assessment results gives a profile quickly meaningful to raters, counselors, and industrial personnel managers. In contrast to reading lengthy and detailed test results, this profile sheet gives, in one glance, a complete picture of an individual's strengths and weaknesses as they might be applied to any number of work situations.

Psychometric testing of academic capabilities and academic achievement is very fine for pupils whose career objectives may be higher education and the professions. For pupils planning to enter the service occupations or trade training, particularly low level trade training, it is a very inappropriate and inadequate approach. Nobody denies that to be academically strong is good in any situation. However, being academically strong is not a prerequisite to successful exercising of the many other inborn attributes applicable to work. To assume that academic weakness implies weakness in the physical attributes of dexterity, discrimination, visualization, and retention is fallacy. Many times people who are considered retarded when measured by conventional and rather singular instruments can demonstrate unusual strengths in functional characteristics if given a chance with proper tests and materials.

(6) Employee Handbook. Contains policies, procedures, job descriptions, and "how-to-do-your-job" guidelines, so that a student can function with a minimum of formal instruction. In the PRO-file section of the handbook, students are invited to retain representative samples of their work to form a set of credentials, which can be shown to potential employers after graduation.

(7) Staff Meeting Units. There are 30 units, each consisting of from two to eight visuals and commentaries, which students use to conduct business meetings. They call for the presentation and discussion of specific policies, procedures, and other business related subjects. In addition they realistically train students in preparing for a meeting, making an agenda, reserving a meeting room, conducting a meeting, etc.

(8) Mail Input Envelopes. Each week a mail input envelope provides the incoming mail. These envelopes, 36 in all, contain a total of more than 1,500 letters. These letters provide the key to a great deal of related activities. To answer them they require research, give opportunities for transcribing dictation notes and demand retrieval and filing. Together with the correspondence in the special projects book, they will require some 4,000 plus letters in answer.

The material in the APEX program will supply some 540 classroom hours each of practical work for 20 students. They are sufficient for 20 students working three hours a day, five days a week for 36 weeks. The materials can be adapted to accommodate smaller or larger groups working fewer or more hours for a longer or shorter period of time.

Tests of Discrimination of objects by size, shape, color and touch, are shown below:

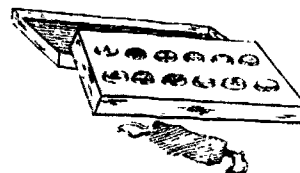
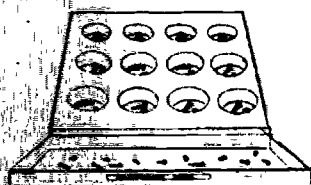

These could relate to:

Electronic Assembly

Art

Osteopathy

Dentistry

Watchmaking

Body and Fender

Hardware Packaging

Flower Arranging

Decorating

Drafting

Health Related

TEST 5 & 6

DEXTERITY - NO TOOLS

It is interesting to note that many people who appear entirely incapable when attempting to work with tools, appear surprisingly capable when given the opportunity to demonstrate dexterity in handling raw materials without tools.

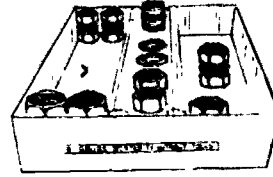
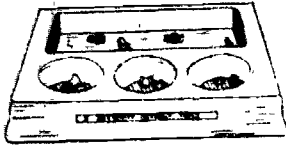

Relate these to such as:

Factory Assembly

Electronic Component Layout

Mail Sorting

Partsman

Ceramics

Hardware Packaging

Bookbinding

#### TEST 7

#### FINE DEXTERITY TEST

The Talent Assessment Programs Small Tools Test utilizes one hand and two hand operations.

The results from this test are quite meaningful to those who might be interested in such things as:

Data Processing

Laboratory Technician

Office Machine Repair

Electronics Service

Sewing (hand)

Jewelry Making

Negative Retouching

Dentistry

Watchmaking

Dental Technician

Surgery

Instrument Technician

Electronics Assembly

Appliance Service

Photo Coloring

Factory Bench

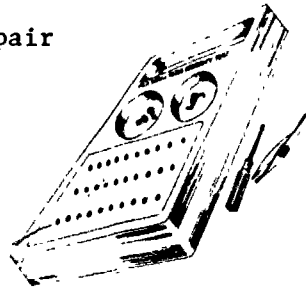

It requires about fifteen minutes for preparation and administration.  
The development of local norms is imperative.



**TEST 8****DEXTERITY WITH LARGER TOOLS**

The Large Hand Tools Dexterity Test is utilized to determine a pupils capacity to handle medium or large size tools. The results are immediately meaningful to people who are entertaining interest in any of the numerous fields of mechanics. Use of this test requires about five minutes of preparation and ten minutes of actual testing. It may be used on both men and women where workshop activities and/or factory production types of work are anticipated. The production of local norms is imperative. This test is related to work in --

**Automotive Mechanics**

Body and Fender

Cabinet Making

Upholstering

Small Engine Service

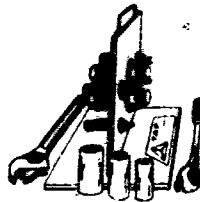
**Major Appliance Service**

Small Appliance Service

Farm Equipment Assembly

Office Machine Repair

Welding

**TEST 9****CIRCUITAL VISUALIZATION**

In this age when electricity and electronics play an ever-increasing role, it is quite important that we measure capacities for circuitual visualization. This can be accomplished with a test such as that which follows.

Norms for this test can be established after about 100 people have taken it.

Although not commonly attempted, it is possible to measure a person's capacity to retain detail related to circuitry.

This test should be administered only to those people who express a desire to learn of their strengths and/or weaknesses in circuitual visualization.

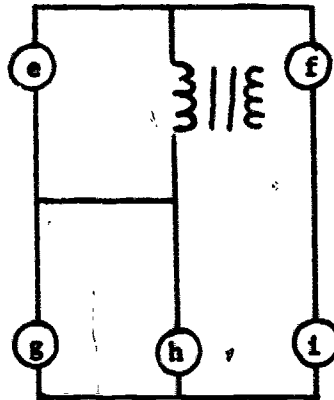
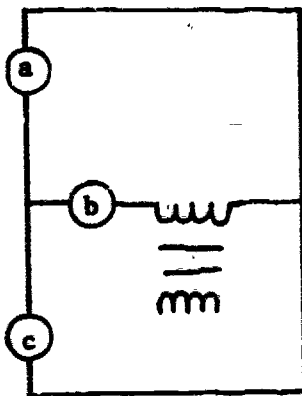

Relate these to such as:

Electric Wiring

Power Transmission

Telephone Service

Appliance Service

Auto Electrical

Drafting

Factory Assembly

Electronics

TEST 10

RETENTION OF STRUCTURAL AND MECHANICAL DETAIL



The retention of detail is quite important to a successful worker. Approximately two hours following the measurement of visualization, the same procedure should be exercised except the model or pattern is not present.

When norms are being developed on this test, remember it is imperative that this time-lapse between the giving of the visualization tests and this one be relatively constant. An approximate two hour lapse works well.

## TEST 11 STRUCTURAL AND MECHANICAL VISUALIZATION IN GREATER DEPTH

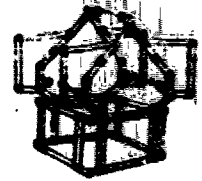

If a person is of relatively high intelligence and appears exceptionally strong on the first test of mechanical and structural visualization, he should be given an opportunity to attempt the more difficult VISUALIZATION TEST.

This test should be offered only to people who might be potential engineers, engineer's helpers, or draftsmen.

Relate this to such as:

Design Engineering

Utility Engineering

Environmental Control

Drafting Engineering

Structural Engineering

Maintenance Eng.

### DIRECTIONS FOR TESTING

1. Tests of dexterity, discrimination, and measuring should be administered on sturdy tables, not occupied in part by other clients.
  2. Make certain that clients have complete understanding of test directions, even if it is necessary to read, demonstrate, and question them.
  3. Without exception the directions must always be the same. To insure this, they should be read from the Work Sheet.
  4. Generally speaking, it is not necessary to give the tests in the order of listing. Exceptions to this are #'s 1, 10, & 11.
- Tests #7 and #8 should be given on tables entirely apart from the other tests.

Tests #3 and #7 should be in strong light equivalent to that which is considered adequate for art work or drafting. Normal reading light is sufficient for all other tests.

Since this is group testing, the starting and finishing times should be taken from a continuous timer that reads in tenths of a minute. For purposes of norming and profiling, errors are converted into additional minutes. The tests are given under standard work-limit conditions.

The threaded sections of bolts and screws should be wiped occasionally with an oily rag. This will insure smooth and uniform action.

ASSESSMENT OF ORIGINAL CHARACTERISTICS

"A" PROFILE

Name \_\_\_\_\_ F. Date January 29, 1973

Age 17 Grade Level Completed 12 School/Organization Central Catholic High  
Grand Island, Nebraska

Work Experience \_\_\_\_\_

Tester \_\_\_\_\_

NORM SCALE

0 10 20 30 40 50 60 70 80 90 100

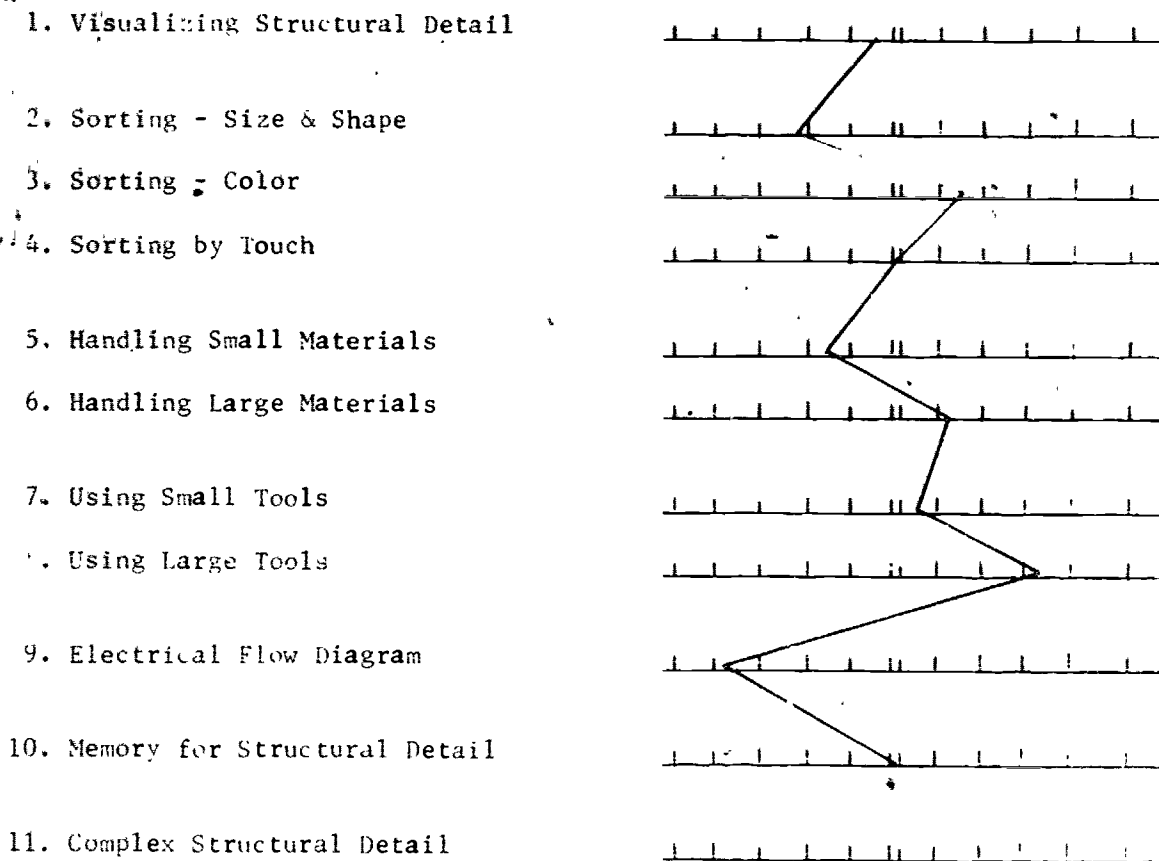

NOTES:

With 7 of the 10 assessments near or to the left of center, Kay may feel a desire to seek training and employment in general work areas rather than in industrial or technical lines. She does use regular or larger tools and handles materials well enough to work at about the semi-skilled level on an industrial assembly line if she desired. She might like to review the TAP papers that relate the individual tests to specific jobs and read about those job possibilities in the Occupational Outlook Handbook. If she desires general work areas she should review the U.S. Office of Education Cluster outline and possibly be surprised to find that there may be more career opportunities in the general areas than in specific lines. These are also described in the Handbook.

T.Q. (Talent Quotient) 103



The test results are profiled in a manner that gives a ten-second readout in the language of employment Personnel. As you study the enclosed profile sheets please bear in mind that these are all action tests - no paper tests. People thoroughly enjoy taking them. They are applicable to all ages above twelve and to all mental levels above trainables. Some of them can be used on trainables. It is not unusual to see special education people, who read at the second grade level, doing better than college graduates on test nine, VISUALIZATION OF FLOW PATHS IN ELECTRICITY. They then go on to take training and employment as electrician's helpers if their dexterities support it.

Norms have been developed on seven different people classifications.

TALENT ASSESSMENT PROGRAMS manufactures and sells the tests used in assessment of inherent characteristics or contracts to do the testing where schools, industries, and manpower programs are located reasonably close.

The assessment kits come in four sizes:

#1	1 to 5 people at one time	\$1500	The cost includes training up to four staff people in testing. Kits 1 & 2 at Des Moines and 3 & 4 at your location.
#2	6 to 10 people at one time	\$1850	
#3	11 to 15 people at one time	\$1950	
#4	16 to 20 people at one time	\$2100	

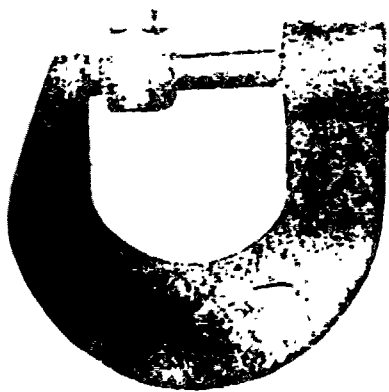

TEST RELATED INFORMATION

SENIOR HIGH MALES - a sample

TEST #	NUMBER	MEAN	STANDARD DEVIATION	COEFFICIENT OF VARIATION
1	331	11.46	3.09	27.0%
2	330	2.92	8.3	35.2%
3	311	5.61	2	25.7%
4	328	4.52	1.96	43.4%
5	324	10.25	2.24	21.9%
6	300	5.49	1.47	26.8%
7	316	7.84	1.7	21.7%
8	325	8.16	2.2	24.5%
9	308	4.01	1.69	42.0%
10	316	10.77	3.27	30.4%

Content validity is insured by using materials and tools of the trades.

The coefficient of stability obtained by limited retesting at the junior high level is .88 with a six month interval.

Further standardization material is being developed under the direction of Dr. Richard D. Brooks - Drake University.

No two tests are designed to measure the same thing.

Discrimination risk is avoided through the use of oral directions.



Any person is comprised of two basic potential segments:

**FUNCTIONAL POTENTIALS**

Measured by T.Q.

THE TALENT QUOTIENT relates to the functional capacities applicabl. to THINGS and MATERIALS in the world of work.

**ACADEMIC POTENTIALS**

Measured by I.Q.

Relates primarily to capacity to apply logic in solving problems in the field of intangibles. Foundation of the professions.

Objective assessment of native capacities is not to be confused with interest exploration and occupational information programs such as Singer-Graflex, JEVS, and others. The programs are complimentary in that much time is saved in exploration when pupils are guided in interest exploration and work activities by knowledge of strengths and weaknesses as shown by the profile. Much frustration is avoided when people do not attempt the things for which they are not fitted.

Wilton E. Nighswonger



## APEX

### The Office: Reality Training Through Simulation

3M Company - Visual Products Division  
3M Center, Bldg. 220-10W  
St. Paul, Minnesota 55101  
(612) 733-7061

APEX represents the American Paper Exporters Association, a fictitious organization modeled after a real one that serves the American Paper Industry. The company serves as the major organization for an office education program (The Office: Reality Training through Simulation) which allows teachers to turn a classroom into an operating business office for reality training through simulation. Although the office simulation program was designed for training, work attitudes as well as skills are emphasized. Consequently, the program is designed to reinforce preparation for work which deals with skills as well as work attitudes such as resourcefulness, pride, promptness, etc. The program was also designed to emphasize evaluation of performance. Evaluation is completed through observation and written records.

The major vehicle for the office simulation program is APEX. The instructor, as office manager, selects students for jobs in APEX after students formally apply and are interviewed. Ten entry level positions available for hiring are typist, file clerk, machine operator, regional clerk, copy clerk, design clerk, billing clerk, payroll clerk, mail clerk, and receptionist. Promotions are made to three intermediate positions of machine specialist, general clerk, and communications specialist and one top

position of clerk typist. The instructor can create other positions to accommodate ability levels of students.

Components which make up the total program are an office manager's guide, transition units, critical incidents, masters book, special projects, employee handbooks, staff meeting units, and mail input envelopes. Further descriptions of these components are as follows:

(1) Office Manager's Guide. Gives the program rationale, the structure of APEX, plus detailed guidelines for conducting the model office's business. Everything the instructor needs to know to get APEX functional is included.

(2) Transition Units. Making the transition from classroom to office is accomplished with the help of nine transition units, which consist of visuals and text for the instructor to explain APEX and its operation to the students.

(3) Critical Incidents Booklet. Every office worker has personality conflicts and suffers from interruptions, and disappointments. There are 50 incidents to be role-played during the course. They are carefully selected to develop decision making skills on the part of the students.

(4) Masters Book. Every business needs letterheads, office forms, etc. The Masters Book contains all of the forms used at APEX, which can be duplicated inexpensively for use by students.

(5) Special Projects Book. Several special projects are provided in a separate booklet which the instructor can use at his discretion. They provide opportunities for practicing skills such as arranging for executive travel, hosting conventions, preparing speeches, etc.

(6) Employee Handbook. Contains policies, procedures, job descriptions, and "how-to-do-your-job" guidelines, so that a student can function with a minimum of formal instruction. In the PRO-file section of the handbook, students are invited to retain representative samples of their work to form a set of credentials, which can be shown to potential employers after graduation.

(7) Staff Meeting Units. There are 30 units, each consisting of from two to eight visuals and commentaries, which students use to conduct business meetings. They call for the presentation and discussion of specific policies, procedures, and other business related subjects. In addition they realistically train students in preparing for a meeting, making an agenda, reserving a meeting room, conducting a meeting, etc.

(8) Mail Input Envelopes. Each week a mail input envelope provides the incoming mail. These envelopes, 36 in all, contain a total of more than 1,500 letters. These letters provide the key to a great deal of related activities. To answer them they require research, give opportunities for transcribing dictation notes and demand retrieval and filing. Together with the correspondence in the special projects book, they will require some 4,000 plus letters in answer.

The material in the APEX program will supply some 540 classroom hours each of practical work for 20 students. They are sufficient for 20 students working three hours a day, five days a week for 36 weeks. The materials can be adapted to accommodate smaller or larger groups working fewer or more hours for a longer or shorter period of time.

Evaluation of student performance is provided for in a number of ways:

- (1) Each critical incident and special project offers the opportunity for critique and evaluation.
- (2) Each meeting unit has built into it an evaluation component.
- (3) The instructor by observing the student's performance in the office and reviewing material he produced, can keep an up to date record of the accomplishments of each individual.
- (4) An important part of the program is the evaluation form which is to be completed for each individual every four weeks and is vital as a prerequisite for advancement or promotion.
- (5) A subtle continuous evaluation involving the students themselves is the sequential structuring of certain tasks which for success require each employee to satisfactorily accomplish his particular part of the job, and on time.

APEX can be purchased through the 3M Company.

Visual Products Division  
3M Company  
Box 33100  
St. Paul, Minnesota 55101

Cost

The Office: Reality training through simulation (Instructor's guide, visuals and material for 20 students)	\$1,195.00
Office Manager's Guide (Orders should accompany master package orders)	49.95
Employee Handbook	6.50 (Each)
Student Replacement Supplies (20 Students)	195.00

The materials which require periodic replacement are:

- (a) Employee Handbook
- (b) Booklet of Critical Incidents
- (c) Input Envelopes
- (d) Special Projects Book

References

Visual Products Division - 3M Company. APEX, St. Paul, Minnesota, 78-1772-6248-8 (926.3) MP.

Wright, L. E., Santos, O. J. Jennings, W. E. The Office: Reality Training Through Simulation - A Sampler, St. Paul, Minnesota, Minnesota Mining and Manufacturing Company, 1972.

## Observations and Implications

Dan Kroloff, Chief  
Special Needs Section  
Department of Public Instruction  
Grimes State Office Building  
Des Moines, Iowa 50319

This workshop was conducted in Council Bluffs, Iowa, on March 26 and 27, 1974, for the purpose of reviewing commercial vocational assessment systems. We wanted to know what they are and the value they may have in career education programs conducted in secondary public schools, area vocational and community colleges, and correctional institutions. The following systems were reviewed?

1. The Singer/Graflex Vocational Evaluation System
2. The Jewish Employment and Vocational Service Work Samples
3. The Tower System
4. The Thomosat System
5. The Wide Range Employment Sample Test
6. The APEX
7. Talent Assessment Programs

In reviewing the information presented, it appears that a number of factors relating to the "systems" approach must be considered before purchasing and implementing. It should be pointed out that the workshop presenters represented various levels of relationship to the commercial assessment systems. Commercial marketers were represented as well as those who administer the units from public secondary schools, area vocational schools, correctional institutions, and rehabilitation facilities. University staff who concentrate on the area of vocational assessment were also represented. Since this approach to "hands on" activities for vocational

assessment is in its infancy stage, the presenters merely reflected their own brief experiences related to their particular settings. Therefore, the following commentary is presented in an effort to discuss some implications of using the "systems" approach in career education programs.

### General Area of Assessment

Presently, there is little disagreement that some system of comprehensive assessment be established. It has been indicated that evaluation should include "hands on" assessment in addition to the paper and pencil tests. The information provided in this workshop indicated that there is no specific vocational assessment system marketed that can provide the total comprehensive evaluation desired. Each system has its strengths and weaknesses, and therefore, must be considered only as one "tool" that can be used by skilled personnel to determine either vocational interests, aptitudes, and/or capabilities.

Some doubt exists regarding the validity of the norms of all assessment systems as they relate to competitive work atmospheres. There is acceptance in recognizing that the "systems" approach is only an indicator and a useful "tool" when in the hands of competent personnel.

There is a general acceptance that the success of developing an accurate profile depends upon the ability of the evaluator to perform adequately in directing, observing, and counseling a participant while being evaluated. It is also recognized that the evaluator could make various contributions to other personnel in different disciplines in addition to providing a profile. These contributions could be in the areas of interpreting the profile and making suggestions for program adaptation.



### Terminology

There appears to be some confusion in understanding vocational evaluation, particularly as educators become involved. One area of confusion results from a lack of common usage of terms which describe the various components of vocational evaluation. Most educators are unable to decipher the terminology with the knowledge they have gained through teacher training programs. Some examples of terms used synonymously are: vocational evaluation, vocational assessment, work evaluation, and job analysis; work samples and work tasks; and work evaluator and vocational evaluator. This terminology or jargon seems to be more consistent with those in rehabilitation than in any other discipline. Today, with the term "Career Education" implying a broader meaning than "Vocational Education," there is a need to clearly interpret terminology in order to promote a better understanding of the vocational evaluation process as it relates to vocational preparation and job placement.

The evaluation of performance skills has largely been left up to rehabilitation personnel. However, the evaluation of performance skills should not be reserved for the rehabilitation discipline. More often than not, interpretation of the results of an evaluation does not promote integrated discipline involvement such as teacher training personnel and a "team" approach concept, although the implications are there. It appears that the evaluators could provide more valuable information to other professionals working with the same population so that interpretation would not be foreign to those in education.

### Persons Served

It is quite evident that the commercial systems are being used with different populations. It must be pointed out that the "systems" could

have different implications when used with the (a) nondisabled youth and adults in educational programs, (b) disadvantaged and handicapped youth and adults in special programs and (c) population served on an individual basis; i.e., rehabilitation clients, corrections population, welfare recipients, etc. The approach used for each individual may vary with respect to the objective which needs to be accomplished. For some, the experience may be vocational awareness, or exploration and for others evaluation of specific vocational skills may be necessary.

There has been little discussion as to the necessary preparation that some groups of individuals may need prior to going through an assessment system. It has been suggested that there may be value in repeating assessment activities more than once or twice with some individuals. This, again, depends upon the objective to be achieved.

There has been little discussion or evidence presented that assessment systems can benefit populations without physical, mental, or cultural limitations.

There appears to be some differences of opinion regarding the number of persons that could be served at one time by commercial systems. The numbers range from five to twelve at any one time depending upon the system used and the individuals participating.

#### Educational Program Change

It appears that evaluation does indicate individual interests, aptitudes, and capabilities which can provide educators with criteria for adaptation of curriculum to satisfy individual needs. The individual profile and related information has implications for related instruction, specialized counseling,

vocational exploration and skill training, and identification of special individual needs. This type of information can assist the school in promoting individualized attention within a general program concept that may range in degree from serving the nonacademic student to the more academically inclined. This implies the use of teacher aides, team teaching, resource rooms, educational specialists, and paraprofessionals from the community.

Individual profiles and dialogue from evaluators should assist educators in reviewing existing curriculum in its relationship to satisfying individual needs. This review could lead to curriculum change. Areas of change could revolve around realistic competencies as they relate to career development and skill training.

Utilizing the "systems" data for program change, could promote the identification of more tangible objectives so that educators can spell out who's going to be served, what and how it's to be done and how well and when.

Understanding and using systems data indicates the need for other discipline (school and community) involvement in planning the total program concept. Utilization of the information could contribute to the role and responsibility of school personnel from the areas of guidance, special and regular academic instruction and career education personnel. Community representatives from areas of rehabilitation, employment, welfare, and industry definitely should have various degrees of involvement in the process. Inservice for all personnel is necessary to encourage appropriate directions. It is necessary to orient all who are involved on what's being attempted, the role and responsibility of each and models for deciding program direction and ongoing review for necessary program change.

Program change may imply flexible scheduling and modular programming so that students are not "locked in" by traditional curriculum areas as promoted generally by traditional educational structure. This approach can provide students the opportunity to move "in and out" of classroom and laboratory areas as individual adjustment and progress indicates.

### Teacher Training

Directions are quite evident for teacher training programs as a result of the exposure to the "systems" units. Institutions offering teacher training programs should involve all departments who are training personnel in education and related areas in building additional concepts into courses that are related to career education. Training institutions can conduct inservice activities to identify present program activity and upgrade personnel responsible for each program. At the same time, criteria should be established for preservice programs in the preparation of new personnel. Teacher training staff should be provided opportunities to communicate, share information, and plan and implement with their colleagues from varying disciplines to promote comprehensive and total career education programming. These few suggestions reflect the feedback from the use of assessment systems.

### Follow-up

Schools have not demonstrated the ability to retrieve meaningful data relating to the implications that assessment techniques imply. The existing assessment data available to educators is utilized very little in program change even though this data has meaning for that change. The assessment approaches reviewed at this workshop only reinforce the need to

look at the assessment information and program results in order to pursue appropriate and meaningful directions. The evaluation component including the follow-up on what happens to people is necessary for educators in determining whether existing programs are justified. Educators cannot continue to rely on assumed educational activities that are good for all students. It is necessary for educators to become more involved in the follow-up process so that they become more realistic in determining whether objectives and goals are accomplished. Utilization of assessment systems promote this direction.

### Conclusion

The purpose of this workshop was to: (1) identify career assessment systems available for purchase (2) review the characteristics of each, and (3) explore the potential utilization of the "systems" components in educational settings (schools).

Even though work evaluation has been pioneered by rehabilitation services, it is quite evident that many of these evaluation components could be beneficial to educators in helping young people make realistic vocational decisions. The justification and acceptance of the vocational evaluation systems in schools must be guided by defined boundaries and tangible objectives with a commitment for program change (adaptation).

Educators must make a decision on whether appropriate vocational directions should be provided young people only by the use of the written word or by utilizing work experience and/or work exploration through work samples in addition to the written word. The amendments to the Vocational Education Act as well as other efforts in promoting work awareness and

vocational skill training promotes the necessary challenge. It is now up to all disciplines that can contribute to provide the comprehensive effort in helping young people more accurately identify their vocational potential. Educators should be able to utilize many of the evaluation components from the commercial systems on the market today, however, at the same time this effort must reflect realistic objectives in meeting individual needs as related to fulfilling manpower demands.

Dan Kroloff



130